

LMP 902-903 series

Filter element according to DIN 24550

Maximum pressure up to 20 bar - Flow rate up to 3000 l/min



The correct filter sizing have to be based on the variable pressure drop depending by the application. For example, for the return filter the pressure drop have to be in the range 0.4 - 0.6 bar.

The pressure drop calculation is performed by adding together the value of the housing with the value of the filter element. The pressure drop in the housing is proportional to the fluid density (kg/dm³); all the graphs in the catalogue are referred to mineral oil with density of 0.86 kg/dm³.

The filter element pressure drop is proportional to its viscosity (mm²/s), the corrective factor Y is related to an oil viscosity different than 30 mm²/s.

Sizing data for single cartridge, head at top

Δp_c = Filter housing pressure drop [bar]

Δp_e = Filter element pressure drop [bar]

Y = Multiplication factor Y (see correspondent table), depending on the filter element size, on the filter element lenght and on the filter media

Q = flow rate (l/min)

V1 reference viscosity = 30 mm²/s (cSt)

V2 = operating viscosity in mm²/s (cSt)

$\Delta p_e = Y : 1000 \times Q \times (V2/V1)$

$\Delta p_{Tot.} = \Delta p_c + \Delta p_e$

Calculation examples with HLP Mineral oil Variation in viscosity

Application data:

Top tank return filter

Filter with in-line connections

Pressure Pmax = 10 bar

Flow rate Q = 120 l/min

Viscosity V2 = 46 mm²/s (cSt)

Oil viscosity = 0.86 kg/dm³

Required filtration efficiency = 25 µm with absolute filtration

With bypass valve and 1 1/4" inlet connection

From the working pressure and the flow rate we understand it should be possible using the following top tank return filter series: MPT, MPH and FRI. Let's proceed with MPT series.

The size 20 doesn't achieve the required flow rate, therefore we have to consider the size 100. The final version of size 100 (101, 104, 110, 120 and 114) will be then defined in function of the mounting characteristics.

$\Delta p_c = 0.03 \text{ bar}$ (* see graphic below, considering size 100 with the max available lenght to get the lowest pressure drop)

$\Delta p_e = (2.0 : 1000) \times 120 \times (46/30) = 0.37 \text{ bar}$

$\Delta p_{Tot.} = 0.03 + 0.37 = 0.4 \text{ bar}$

The selection is correct because the total pressure drop value is inside the admissible range for top tank return filters. It is of course possible trying to find a different solution, according to the mounting position or to other commercial need, repeating the previous steps while using a different series or lenght.

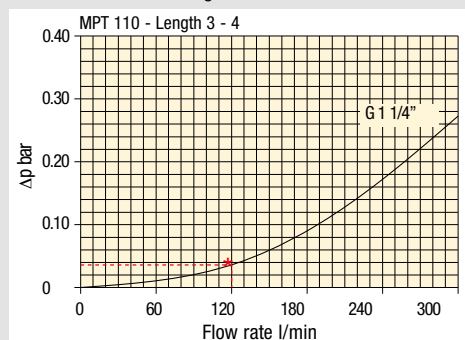

Filter housings Δp pressure drop.

The curves are plotted using mineral oil with density of 0.86 kg/dm³ in compliance with ISO 3968. Δp varies proportionally with density.

Corrective factor Y, to be used for the filter element pressure drop calculation. The values depend to the filter size and lenght and to the filter media.

Reference viscosity 30 mm²/s

Return filters

Filter element	Absolute filtration H Series					Nominal filtration N Series			
	Type	A03	A06	A10	A16	A25	P10	P25	M25 M60 M90
MF 020	1	74.00	50.08	20.00	16.00	9.00	6.43	5.51	4.40
	2	29.20	24.12	8.00	7.22	5.00	3.33	2.85	2.00
	3	22.00	19.00	6.56	5.33	4.33	1.68	1.44	1.30
MF 030 MFX 030	1	74.00	50.08	20.00	16.00	9.00	6.43	5.51	3.40
MF 100 MFX 100	1	28.20	24.40	8.67	8.17	6.88	4.62	3.96	1.25
	2	17.33	12.50	6.86	5.70	4.00	3.05	2.47	1.10
	3	10.25	9.00	3.65	3.33	2.50	1.63	1.32	0.96
	4	6.10	5.40	2.30	2.20	2.00	1.19	0.96	0.82
MF 180 MFX 180	1	3.67	3.05	1.64	1.56	1.24	1.18	1.06	0.26
	2	1.69	1.37	0.68	0.54	0.51	0.43	0.39	0.12
MF 190 MFX 190	2	1.69	1.37	0.60	0.49	0.44	0.35	0.31	0.11
MF 400 MFX 400	1	3.20	2.75	1.39	1.33	1.06	0.96	0.87	0.22
	2	2.00	1.87	0.88	0.85	0.55	0.49	0.45	0.13
	3	1.90	1.60	0.63	0.51	0.49	0.39	0.35	0.11
MF 750 MFX 750	1	1.08	0.84	0.49	0.36	0.26	0.21	0.19	0.06
CU 025		78.00	48.00	28.00	24.00	9.33	9.33	8.51	1.25
CU 040		25.88	20.88	10.44	10.00	3.78	3.78	3.30	1.25
CU 100		15.20	14.53	5.14	4.95	2.00	2.00	0.17	1.10
CU 250		3.25	2.55	1.55	1.35	0.71	0.71	0.59	0.25
CU 630		1.96	1.68	0.85	0.72	0.42	0.42	0.36	0.09
CU 850		1.06	0.84	0.42	0.33	0.17	0.17	0.13	0.04
MR 100	1	19.00	17.00	6.90	6.30	4.60	2.94	2.52	1.60
	2	11.70	10.80	4.40	4.30	3.00	2.94	2.52	1.37
	3	7.80	6.87	3.70	3.10	2.70	2.14	1.84	1.34
	4	5.50	4.97	2.60	2.40	2.18	1.72	1.47	1.34
	5	4.20	3.84	2.36	2.15	1.90	1.60	1.37	1.34
MR 250	1	5.35	4.85	2.32	1.92	1.50	1.38	1.20	0.15
	2	4.00	3.28	1.44	1.10	1.07	0.96	0.83	0.13
	3	2.60	2.20	1.08	1.00	0.86	0.77	0.64	0.12
	4	1.84	1.56	0.68	0.56	0.44	0.37	0.23	0.11
MR 630	1	3.10	2.48	1.32	1.14	0.92	0.83	0.73	0.09
	2	2.06	1.92	0.82	0.76	0.38	0.33	0.27	0.08
	3	1.48	1.30	0.60	0.56	0.26	0.22	0.17	0.08
	4	1.30	1.20	0.48	0.40	0.25	0.21	0.16	0.08
	5	0.74	0.65	0.30	0.28	0.13	0.10	0.08	0.04
MR 850	1	0.60	0.43	0.34	0.25	0.13	0.12	0.09	0.03
	2	0.37	0.26	0.23	0.21	0.11	0.08	0.07	0.03
	3	0.27	0.18	0.17	0.17	0.05	0.04	0.04	0.02
	4	0.23	0.16	0.13	0.12	0.04	0.03	0.03	0.02

Corrective factor Y, to be used for the filter element pressure drop calculation.
The values depend to the filter size and lenght and to the filter media.

Reference viscosity 30 mm²/s

Suction filters

Filter element	Nominal filtration N Series	
	P10	P25
SF 250	65	21

Return / Suction filters

Filter element	Absolute filtration			
	A10	A16	A25	
RSX 116	1	5.12	4.33	3.85
	2	2.22	1.87	1.22
RSX 165	1	2.06	1.75	1.46
	2	1.24	1.05	0.96
	3	0.94	0.86	0.61

Low & Medium pressure filters

Filter element	Type	Absolute filtration N-W Series					Nominal filtration N Series		
		A03	A06	A10	A16	A25	P10	P25	M25
CU 110	1	16.25	15.16	8.75	8.14	5.87	2.86	2.65	0.14
	2	12.62	10.44	6.11	6.02	4.15	1.60	1.49	0.12
	3	8.57	7.95	5.07	4.07	2.40	1.24	1.15	0.11
	4	5.76	4.05	2.80	2.36	1.14	0.91	0.85	0.05
CU 210	1	5.30	4.80	2.00	1.66	1.32	0.56	0.43	0.12
	2	3.44	2.95	1.24	1.09	0.70	0.42	0.35	0.09
	3	2.40	1.70	0.94	0.84	0.54	0.33	0.23	0.05
DN	016	7.95	7.20	3.00	2.49	1.98	0.84	0.65	0.18
	025	5.00	4.53	1.89	1.57	1.25	0.53	0.41	0.11
	040	3.13	2.66	1.12	0.98	0.63	0.38	0.32	0.08
CU 400	2	3.13	2.55	1.46	1.22	0.78	0.75	0.64	0.19
	3	2.15	1.70	0.94	0.78	0.50	0.40	0.34	0.10
	4	1.60	1.28	0.71	0.61	0.40	0.34	0.27	0.08
	5	1.00	0.83	0.47	0.34	0.20	0.24	0.19	0.06
	6	0.82	0.58	0.30	0.27	0.17	0.22	0.18	0.05
	CU 900	1	0.86	0.63	0.32	0.30	0.21	-	-
CU 950	2	1.03	0.80	0.59	0.40	0.26	-	-	0.05
	3	0.44	0.40	0.27	0.18	0.15	-	-	0.02
MR 630	7	0.88	0.78	0.36	0.34	0.16	0.12	0.96	0.47

FILTER SIZING Corrective factor

Corrective factor **Y**, to be used for the filter element pressure drop calculation.
The values depend to the filter size and lenght and to the filter media.

Reference viscosity 30 mm²/s

High pressure filters

Filter element	Absolute filtration N - R Series					Nominal filtration N Series	
	Type	A03	A06	A10	A16		A25
HP 011	1	332.71	250.07	184.32	152.36	128.36	-
	2	220.28	165.56	74.08	59.13	37.05	-
	3	123.24	92.68	41.48	33.08	20.72	-
	4	77.76	58.52	28.37	22.67	16.17	-
HP 039	1	70.66	53.20	25.77	20.57	14.67	4.90
	2	36.57	32.28	18.00	13.38	8.00	2.90
	3	26.57	23.27	12.46	8.80	5.58	2.20
HP 050	1	31.75	30.30	13.16	12.3	7.29	1.60
	2	24.25	21.26	11.70	9.09	4.90	1.40
	3	17.37	16.25	8.90	7.18	3.63	1.25
	4	12.12	10.75	6.10	5.75	3.08	1.07
	5	7.00	6.56	3.60	3.10	2.25	0.80
HP 065	1	58.50	43.46	23.16	19.66	10.71	1.28
	2	42.60	25.64	16.22	13.88	7.32	1.11
	3	20.50	15.88	8.18	6.81	3.91	0.58
HP 135	1	20.33	18.80	9.71	8.66	4.78	2.78
	2	11.14	10.16	6.60	6.38	2.22	1.11
	3	6.48	6.33	3.38	3.16	2.14	1.01
HP 320	1	10.88	9.73	5.02	3.73	2.54	1.04
	2	4.40	3.83	1.75	1.48	0.88	0.71
	3	2.75	2.11	1.05	0.87	0.77	0.61
	4	2.12	1.77	0.98	0.78	0.55	0.47
HP 500	1	4.44	3.67	2.30	2.10	1.65	0.15
	2	3.37	2.77	1.78	1.68	1.24	0.10
	3	2.22	1.98	1.11	1.09	0.75	0.08
	4	1.81	1.33	0.93	0.86	0.68	0.05
	5	1.33	1.15	0.77	0.68	0.48	0.04

Filter element	Absolute filtration N Series					Nominal filtration N Series	
	Type	A03	A06	A10	A16		A25
HF 320	1	3.65	2.95	2.80	1.80	0.90	0.38
	2	2.03	1.73	1.61	1.35	0.85	0.36
	3	1.84	1.42	1.32	1.22	0.80	0.35

Stainless steel high pressure filters

Filter element	Absolute filtration N Series					
	Type	A03	A06	A10	A16	A25
HP 011	1	332.71	250.07	184.32	152.36	128.36
	2	220.28	165.56	74.08	59.13	37.05
	3	123.24	92.68	41.48	33.08	20.72
	4	77.76	58.52	28.37	22.67	16.17
HP 039	2	70.66	53.20	25.77	20.57	14.67
	3	36.57	32.28	18.00	13.38	8.00
	4	26.57	23.27	12.46	0.88	5.58
	1	31.75	30.30	13.16	12.3	7.29
HP 050	2	24.25	21.26	11.70	9.09	4.90
	3	17.37	16.25	8.90	7.18	3.63
	4	12.12	10.75	6.10	5.75	3.08
	5	7.00	6.56	3.60	3.10	2.25
	1	20.33	18.80	9.71	8.66	4.78
HP 135	2	11.14	10.16	6.60	6.38	2.22
	3	6.48	6.33	3.38	3.16	2.14

Filter element	Absolute filtration H - U Series					
	Type	A03	A06	A10	A16	A25
HP 011	1	424.58	319.74	235.17	194.44	163.78
	2	281.06	211.25	94.53	75.45	47.26
	3	130.14	97.50	43.63	34.82	21.81
	4	109.39	82.25	36.79	29.37	18.40
HP 039	2	70.66	53.20	25.77	20.57	14.67
	3	36.57	32.28	18.00	13.38	8.00
	4	26.57	23.27	12.46	8.80	5.58
	1	47.33	34.25	21.50	20.50	14.71
HP 050	2	29.10	25.95	14.04	10.90	5.88
	3	20.85	19.50	10.68	8.61	4.36
	4	14.55	12.90	7.32	6.90	3.69
	5	9.86	9.34	6.40	4.80	2.50
	1	29.16	25.33	13.00	12.47	5.92
HP 135	2	14.28	11.04	7.86	7.60	4.44
	3	8.96	7.46	4.89	4.16	3.07

Step 1 Select "FILTERS"



Step 2 Choose filter group (Return Filter, Pressure Filter, etc.)



Step 3 Choose filter type (MPF, MPT, etc.) in function of the max working pressure and the max flow rate



Step 4 Push "PROCEED"

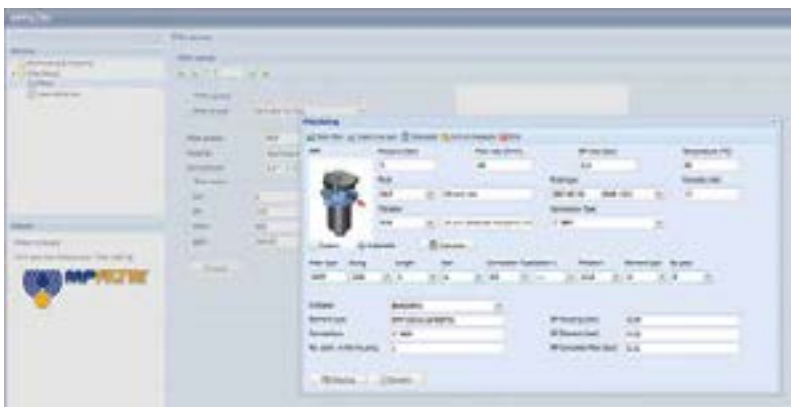

Step 5

Insert all application data to calculate the filter size following the sequence:

- working pressure
- working flow rate
- working pressure drop
- working temperature
- fluid material and fluid type
- filtration media
- connection type

Step 6

Push "CALCULATE" to have result; in case of any mistake, the system will advice which parameter is out of range to allow to modify/adjust the selection

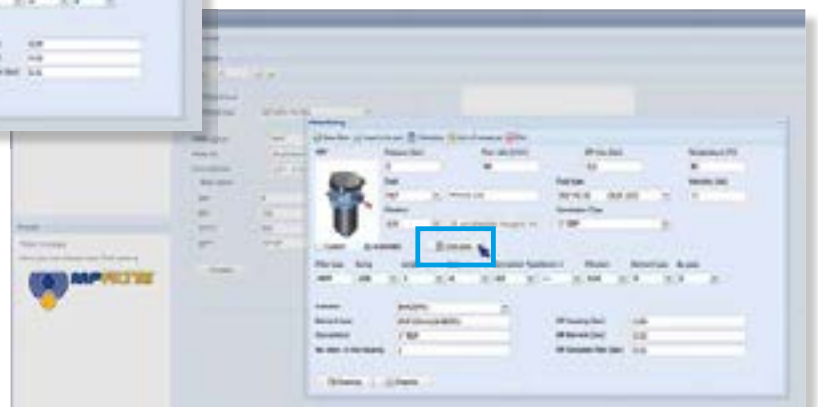

Step 7

Download PDF Datasheet "Report.aspx" pushing the button "Drawing"

LMP 902-903 series

Filter element according to DIN 24550

Maximum pressure up to 20 bar - Flow rate up to 3000 l/min



LMP902-903 GENERAL INFORMATION

Technical data

Low & Medium Pressure filters

Maximum pressure up to 20 bar - Flow rate up to 3000 l/min
Filter element according to DIN 24550

Filter housing materials

- Head: Anodized Aluminium
- Housing: Anodized Aluminium
- Manifolds: Welded - Phosphated Steel
- Bypass valve: Steel
- Size 1000 filter elements complying with DIN 24550 standard

Number of filter elements

- LMP 902: 4 filter elements CU900
- LMP 903: 6 filter elements CU900

Seals

- Standard NBR series A
- Optional FPM series V

Filter elements

- Filter element in according to with DIN 24550
- Size: 1000

Temperature

- From -25 °C to +110 °C

Pressure

- Working pressure: 2.5 MPa (25 bar)
- Test pressure: 3.5 MPa (35 bar)

Δp element type

- Microfibre filter elements - series N: 20 bar
- Fluid flow through the filter element from OUT to IN.

Note

- LMP 902 - 903 filters are provided for vertical mounting

Bypass valve

- Opening pressure 3.5 bar ±10%
- Other opening pressures on request.

Connections

- LMP 902-903: In-line Inlet/Outlet

Weights [kg] and volumes [dm³]

	Weights [kg]		Volumes [dm ³]	
	Length	1	Length	1
LMP 902		89.6		58
LMP 903		129.2		87

Hydraulic symbols

LMP 902 - 952

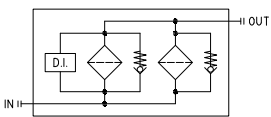

LMP 903 - 953

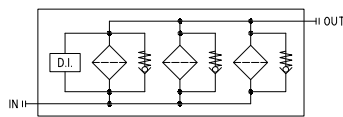

LMP 954

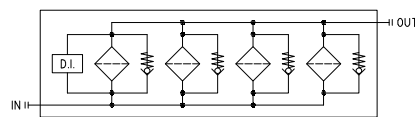

Manifolds

Position of manifolds IN - OUT connections

FA

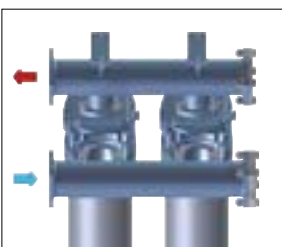

FB

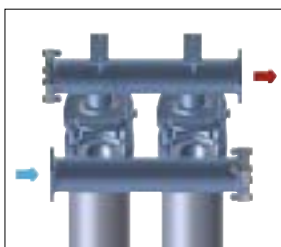

FC

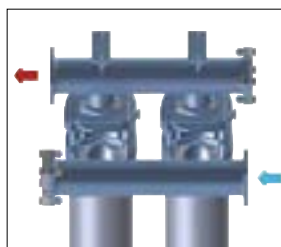

FD

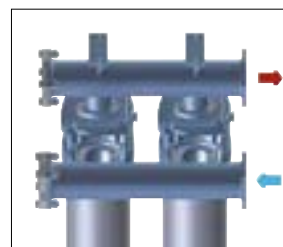

GENERAL INFORMATION LMP902-903

The curves are plotted using mineral oil with density of 0.86 kg/dm³ in compliance with ISO 3968.
 Δp varies proportionally with density.

Pressure drop

Filter housings Δp pressure drop

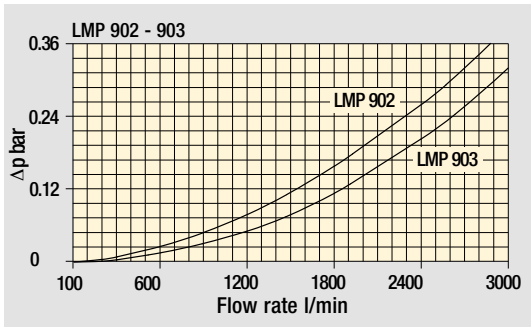

Bypass valve pressure drop

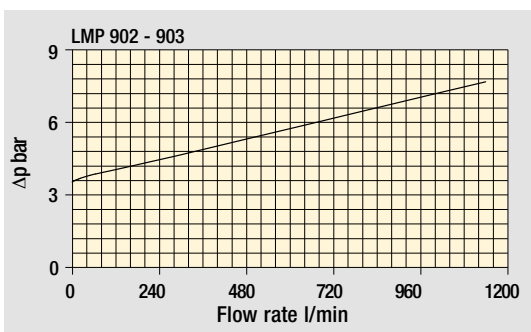

Focus on:

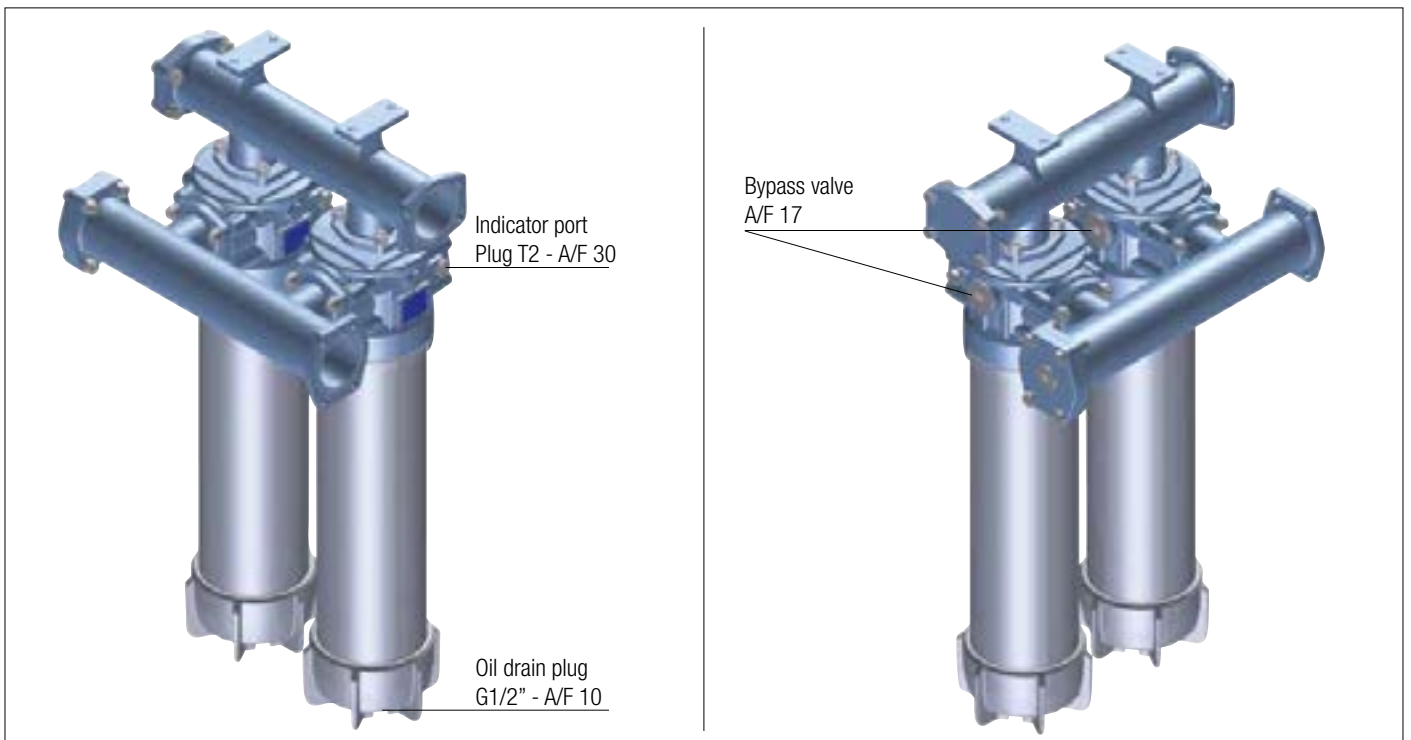

LMP902-903

Designation & Ordering code

COMPLETE FILTER

Series and size LMP902 LMP903		Configuration example: LMP902 2 B A FA A10 N P01							
Length 2									
Bypass valve S Without bypass		B 3.5 bar							
Seals and treatments A NBR V FPM									
Connections		IN		OUT					
FA 4" SAE 3000 psi		left		left					
FB 4" SAE 3000 psi		left		right					
FC 4" SAE 3000 psi		right		left					
FD 4" SAE 3000 psi		right		right					
Filtration rating (filter media)									
A03 Inorganic microfiber 3 µm		M25 Wire mesh 25 µm							
A06 Inorganic microfiber 6 µm		M60 Wire mesh 60 µm							
A10 Inorganic microfiber 10 µm		M90 Wire mesh 90 µm							
A16 Inorganic microfiber 16 µm									
A25 Inorganic microfiber 25 µm									
						Element Δp N 20 bar		Execution P01 MP Filtri standard Pxx Customized	

FILTER ELEMENT

Element series and size CU900		Configuration example: CU900 A10 A N P01							
Filter series and size LMP902 Nr. 4 filter elements LMP903 Nr. 6 filter elements									
Filtration rating (filter media)									
A03 Inorganic microfiber 3 µm		M25 Wire mesh 25 µm							
A06 Inorganic microfiber 6 µm		M60 Wire mesh 60 µm							
A10 Inorganic microfiber 10 µm		M90 Wire mesh 90 µm							
A16 Inorganic microfiber 16 µm									
A25 Inorganic microfiber 25 µm									
Seals A NBR V FPM									
						Element Δp N 20 bar		Execution P01 MP Filtri standard Pxx Customized	

ACCESSORIES

Differential indicators		page		page	
DEA	Electrical differential indicator	419	DTA	Electronic differential indicator	422
DEM	Electrical differential indicator	419-420	DVA	Visual differential indicator	422
DLA	Electrical / visual differential indicator	420-421	DVM	Visual differential indicator	422
DLE	Electrical / visual differential indicator	421			
Additional features		page			
T2	Plug	423			

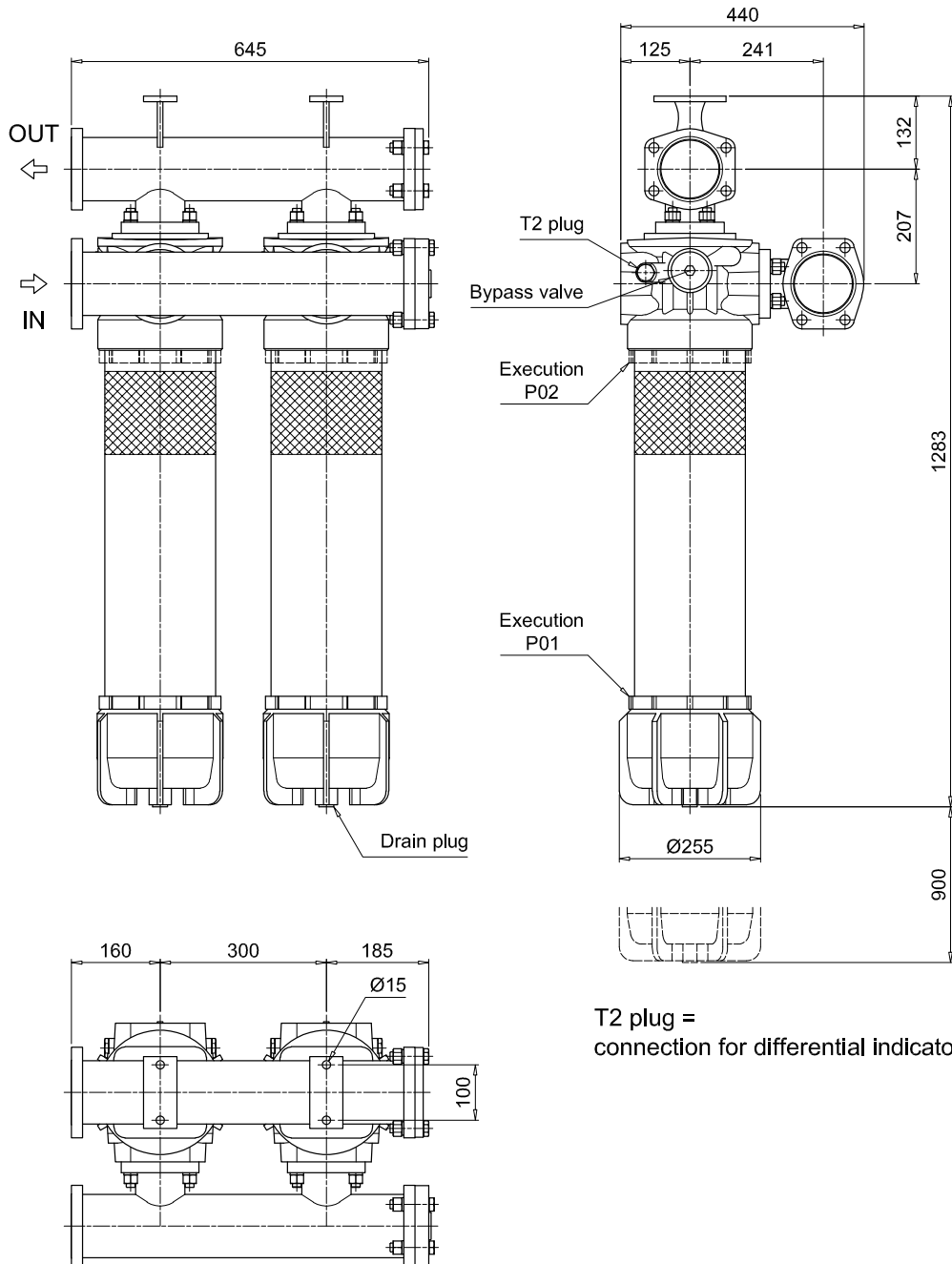

LMP902-903

Dimensions

LMP903

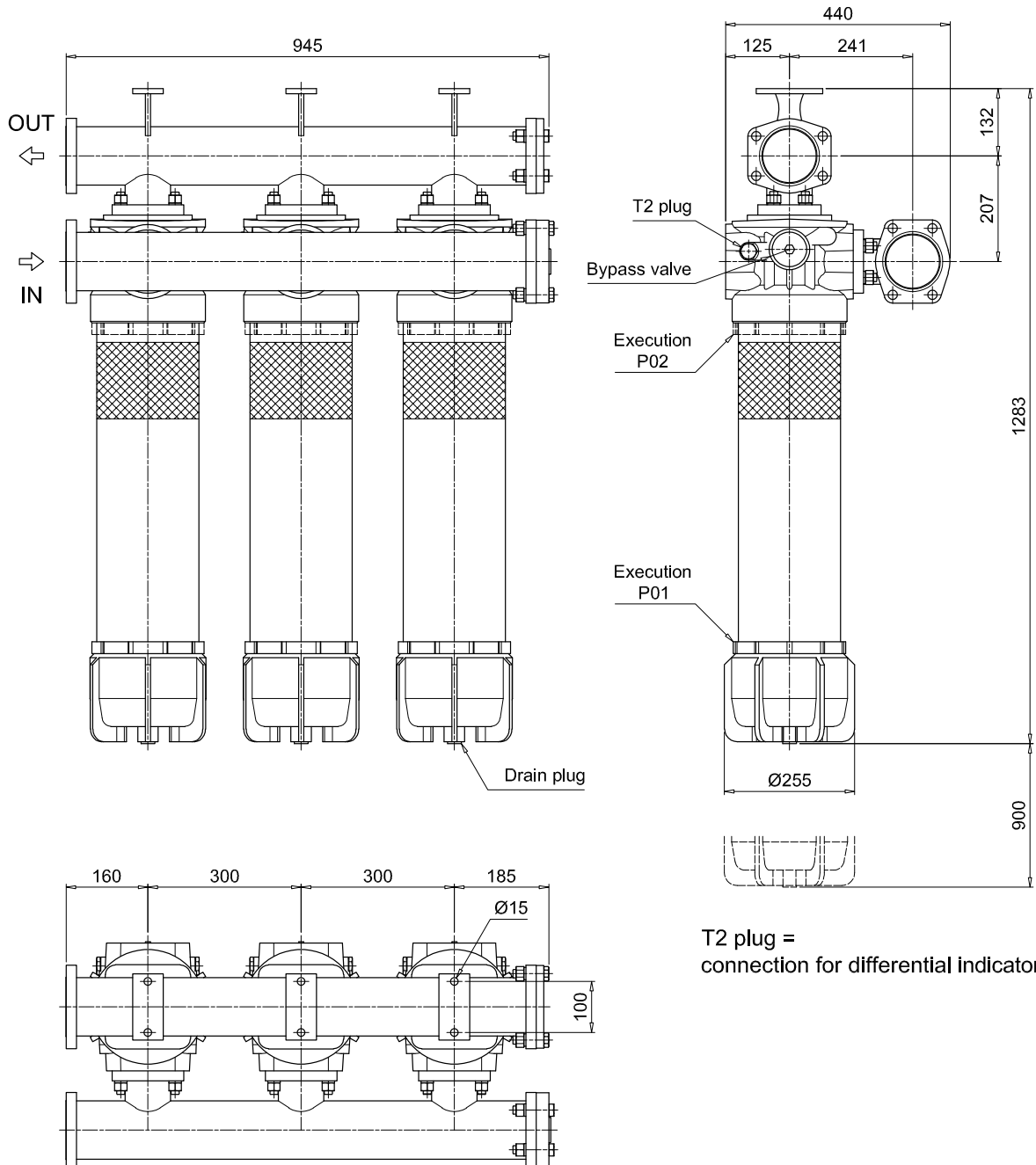

SPARE PARTS LMP902-903

Order number for spare parts

LMP 902 - 903

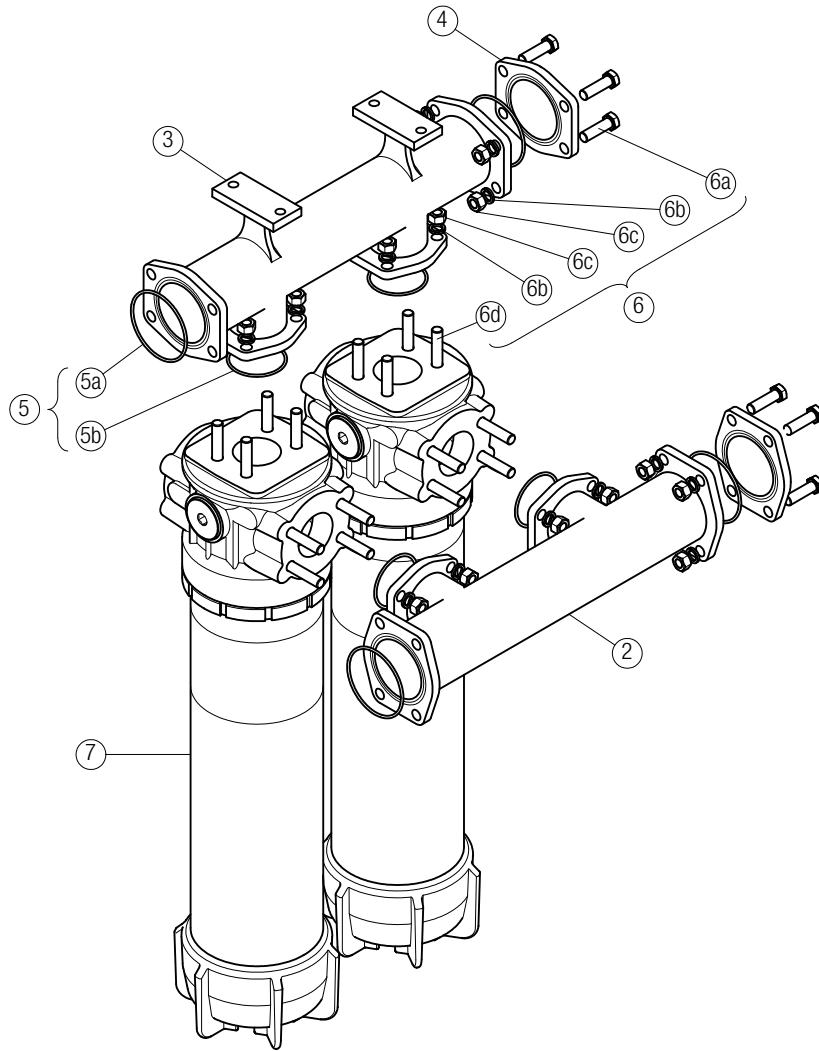

Item 7:
for complete filter code and
spare parts, see
LMP 900 - 901 series chapter

Quantity:
- filter spare parts:
LMP 902 - 2 pcs.
LMP 903 - 3 pcs.

- filter seal kit:
LMP 902 - 2 pcs.
LMP 903 - 3 pcs.

Item:	2		3	4		5 (5a-5b)			6 (6a ÷ 6d)		7	
Filter series	Q.ty	Manifold IN	OUT	4" SAE 3000 psi plugged flange Q.ty	Manifolds seal kit NBR	FPM	Threaded fasteners kit Q.ty	Q.ty	Filter Q.ty			
LMP 902	1 pc.	01039270	01039271	2 pcs.	01042012	1 pc.	02050404	02050405	1 pc.	02049051	2 pcs.	LMP9012xxF1xxxNP02
LMP 903	1 pc.	01039337	01039338	2 pcs.		1 pc.	02050404	02050405	1 pc.	02049052	3 pcs.	