



BS-5200



























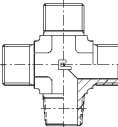
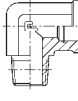
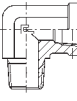
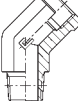
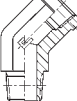
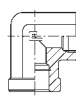
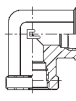
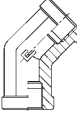
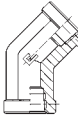
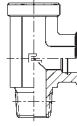
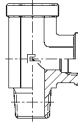
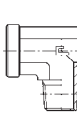
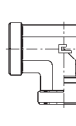
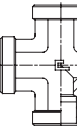
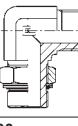
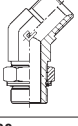
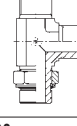
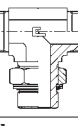
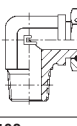
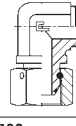
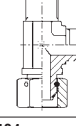
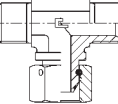
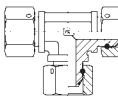

30

BS

AVAILABLE IN CARBON AND STAINLESS STEEL

FIGURATIVE INDEX – FITTINGS BS 5200 - ISO 8434-6

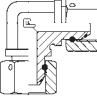
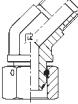
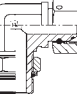
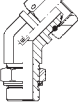
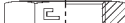
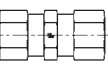
General instructions	Quality assurance	Allowed temperatures	Finish treatments	Tubes to be used	Threaded ends	Prescriptions to comply with
Utilisation standards	Safety factors	Seals on threads	End treatments	Tables follow up	Gas - Metric UNF - NPT	Assembly instructions
Page 158	Page 22	Page 23	Page 24	Page 25-26	Page 27-32	Page 33;39-159
Type: 3001.. BSPT Type: 3002.. NPT 	Type: 3003.. BSPP/con. Type: 3004.. BSPP/NPT 	Type: 3005.. BSPP 	Type: 3005..ATT BSPP 	Type: 3006.. Metric paral. 	Type: 3007.. BSPP/Metric paral. 	Type: 3008.. BSPP Type: 3009.. Metric paral. 
Page 160	Page 161	Page 162-163	Page 164	Page 164	Page 165	Page 166
Type: 3010.. BSPT Type: 3011.. NPT 	Type: 3012.. BSPP Type: 3013.. Metric paral. 	Type: 3014.. BSPT Type: 3015.. NPT 	Type: 3016.. BSPP Type: 3017.. Metric paral. 	Type: 3018.. BSPP Type: 3019.. Metric paral. 	Type: 3020.. BSPT Type: 3021.. NPT 	Type: 3022.. BSPP/con. Type: 3023.. BSPP/NPT 
Page 167	Page 168	Page 169	Page 170	Page 171	Page 172	Page 173
Type: 3024.. BSPP Type: 3025.. Metric paral. 	Type: 3026.. BSPP/con. Type: 3027.. BSPP/NPT 	Type: 3028.. BSPP Type: 3029.. Metric paral. 	Type: 3030.. BSPP/con. Type: 3031.. BSPP/NPT 	Type: 3032.. BSPP/con. Type: 3033.. BSPP/NPT 	Type: 3034.. BSPP Type: 3035.. Metric paral. 	Type: 3036.. BSPP 
Page 174	Page 175	Page 176	Page 177	Page 178	Page 179	Page 180
Type: 3037.. BSPP/NPT 	Type: 3038.. BSPP/con. 	Type: 3039.. NPT 	Type: 3040.. BSPP/con. 	Type: 3041.. NPT 	Type: 3042.. BSPP 	Type: 3043.. NPT 
Page 180	Page 181	Page 181	Page 182	Page 182	Page 183	Page 183
Type: 3044.. BSPP 	Type: 3045.. NPT 	Type: 3046.. BSPP/con. 	Type: 3047.. NPT 	Type: 3048.. BSPP/con. Type: 3049.. NPT 	Type: 3050.. BSPP Type: 3051.. NPT 	Type: 3052.. BSPP Type: 3053.. NPT 
Page 184	Page 184	Page 185	Page 185	Page 186	Page 187	Page 187
Type: 3054.. BSPP Type: 3055.. Metric paral. 	Type: 3056.. BSPP Type: 3057.. Metric paral. 	Type: 3058.. BSPP Type: 3059.. Metric paral. 	Type: 3060.. BSPP Type: 3061.. Metric paral. 	Type: 3062.. BSPP/con. Type: 3063.. BSPP/NPT 	Type: 3064.. BSPP Type: 3065.. Metric paral. 	Type: 3066.. BSPP Type: 3067.. Metric paral. 
Page 188	Page 189	Page 190	Page 191	Page 192	Page 193	Page 194
Type: 3068.. BSPP Type: 3069.. Metric paral. 	Type: 3070.. BSPP Type: 3071.. Metric paral. 	Type: 3072.. BSPP 	Type: 3073.. BSPP 	Type: 3074.. BSPP Type: 3075.. Metric paral. 	Type: 3076.. BSPP Type: 3077.. Metric paral. 	Type: 3078.. BSPP 
Page 195	Page 196	Page 197	Page 197	Page 198	Page 199	Page 200
Type: 3079.. BSPP 	Type: 3080.. BSPP Type: 3081.. Metric paral. 	Type: 3082.. BSPP Type: 3083.. Metric paral. 	Type: 3084.. BSPP Type: 3085.. Metric paral. 	Type: 3086.. BSPP Type: 3087.. Metric paral. 	Type: 0023.. BSPP 	Type: 5010.. BSPP Type: 5011.. Metr. cilind. Type: 5012.. BSPT Type: 5013.. NPT 
Page 200	Page 201	Page 202	Page 203	Page 204	Page 205	Page 205-206

ORDERING EXAMPLES (Carbon steel)

ORDERING EXAMPLES (Stainless steel)

BS

- If you require a straight adapter with 3/4" BSP parallel thread made of carbon steel, order: 300518

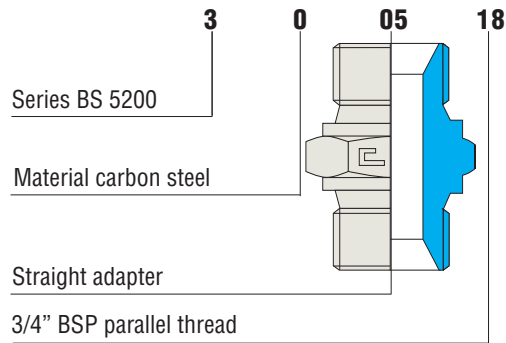

BS

- If you require a straight adapter with 3/4" BSP parallel thread made of stainless steel, order: 310518

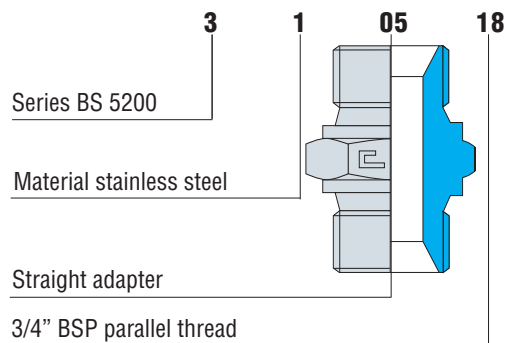

New 60° adapter with elastomeric seal designed by CAST.

BS

- If you require a straight adapter with swivel nut with 3/4" BSP parallel thread made of carbon steel, order: 301606

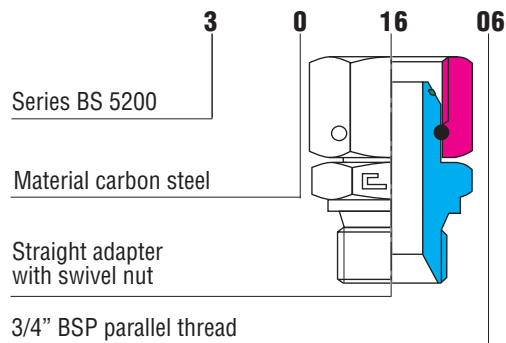

BS

- If you require a straight adapter with swivel nut with 3/4" BSP parallel thread made of stainless steel, order: 311606

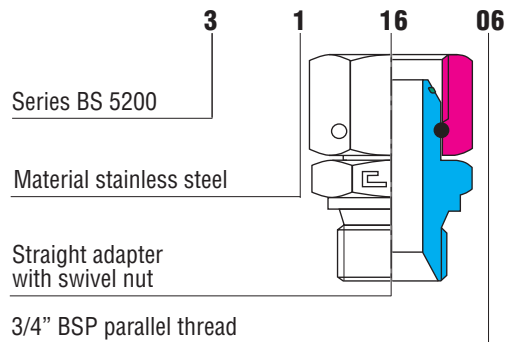

DELIVERIES

- Cast S.p.A. fittings are delivered in the configurations shown in the pictures of this catalogue.
- Available on scheduled orders only: it means that the article is slow moving and will be delivered within 90 days.
- Available on request only: it means that the article is not commonly in stock; please contact our offices for further delivery details.

THEORY OF OPERATION

The Cast fitting, manufactured according to BS 5200, is a mechanical adapter traditionally used for high pressure fluid-dynamic systems. The sealing is made between two conical surfaces, metal to metal, with no deformation of the components, plus an elastomeric sealing (O-Ring) placed into a groove on the 60° cone.

N.B. The elastomeric seal is made according to a CAST S.p.A. project.

The connection between the body of the adapter and the body of the component is guaranteed by the swivel tightening nut and the threaded parts for the other types. It helps fast assembly of removable tubes, avoids welding and tapping, thus assuring maximum simplicity for complex oleo-dynamic systems. Repeated assemblies do not alter the performance of the coupling.

COUPLING SYSTEM BS 5200

Traceability decoding:

CAST =
Logo of the
Manufacturer

- T =
Production plant
- 3 =
Year of manufacture
- CE =
Made in EEC
- 50 =
Type of steel used
- 01 =
Heat number of the
steel used

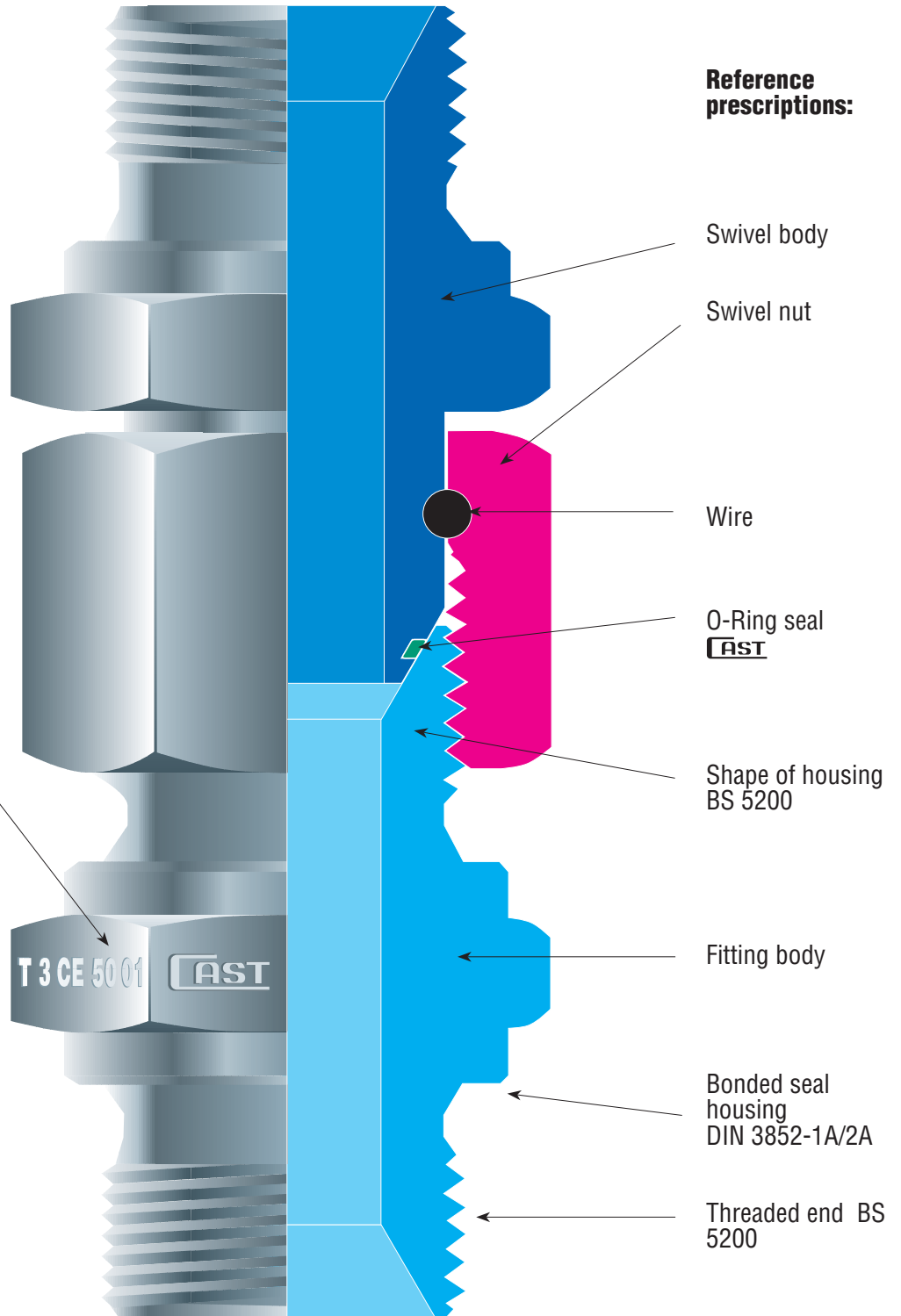

Reference prescriptions:

- Swivel body
- Swivel nut
- Wire
- O-Ring seal
CAST
- Shape of housing
BS 5200
- Fitting body
- Bonded seal
housing
DIN 3852-1A/2A
- Threaded end BS
5200

TECHNICAL CHARACTERISTICS

Cast 60° fittings assure perfect seal regardless of the fluid used, provided that no corrosive fluids be employed, the nominal pressures of the fittings and the indicated temperatures be respected and the prescriptions of the manufacturer be followed scrupulously.

These fittings are manufactured in a single series defined "UNIVERSAL" and combine the various (regulatory) series of fittings: DIN 2353- SAE J514- SAE J1453- SAE J516 etc.

Normal vibrations do not alter the functionality of this type of fitting, also at the top quoted values. Therefore the fitting maintains its best characteristics of absolute guarantee, safety and reliability. For these specific reasons this fitting may be used in hard working conditions.

Under the mechanical strength given by the tightening of the nut on the fitting body, the conical male part couples with the conical female part of the fitting body to provide a very effective metal to metal seal supported by the elastomeric seal as well.

Before assembly

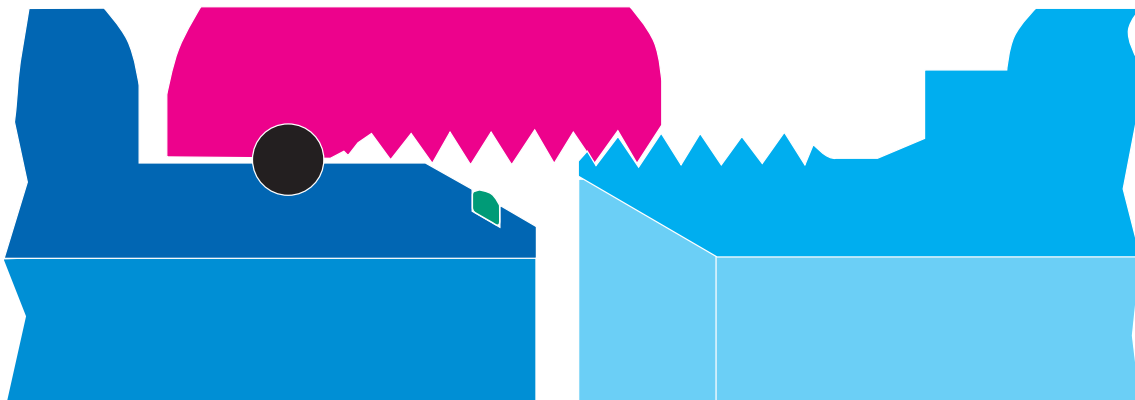

After assembly

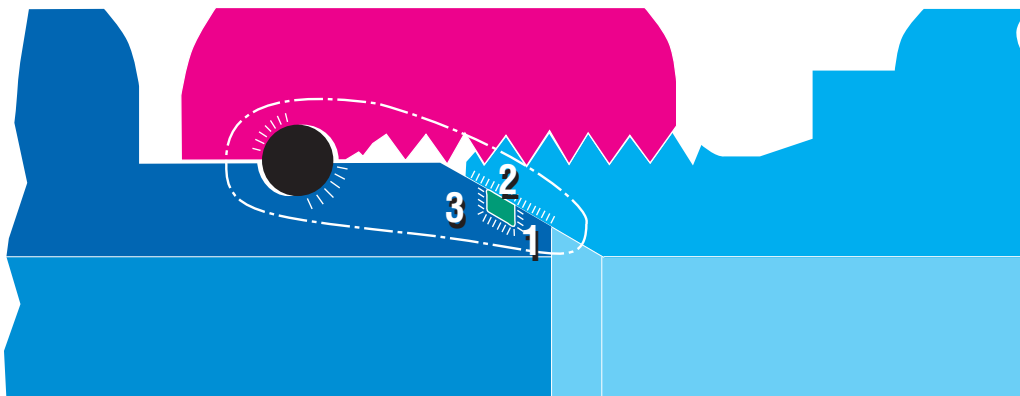

Pressure surfaces



Superfici di pressione



Sealing points

1 - 2 - 3

PRODUCT CONCEPT

- The idea has been to use the standard 60° adapter structure and place an O-ring in the 60° conical part to add an elastomeric seal to the traditional metal to metal seal.
- The new adapter with elastomeric seal solves the problem of small leakages, leaks and sweating that are typical of a metal to metal sealing system on high pressure fittings.
- The introduction of the new adapter with elastomeric seal in any case does not limit the required performance for adapters with or without elastomeric seal.

SEALING

The new adapter solves the total sealing problem in the following way:

- A groove was created on the diameter of the 60° cone as insert place for an O-ring. This elastomeric seal guarantees a perfect seal at all times.
- Creating the groove on the 60° cone has allowed us to improve the metal to metal sealing characteristics by dividing the taper sealing surface of the fitting in two.
- Strenuous tests carried out in our technical laboratory in Casalgrasso (CN) have clarified, beyond any doubt, the reliability of the sealing with or without the O-ring itself.
- We can thus state that this new type of adapter is to be used preferably in combination with the elastomeric seal (O-ring) to ensure a sealing system as dry as dust.
- However, if due to temperature or fluid requirements, the adapter can not be used with the O-ring, the new adapter can be equally used without O-ring, with the certainty that the improved metal to metal seal will ensure the required sealing characteristics.

GENERAL INSTRUCTIONS

- Before starting any operation, please check that all the tools to be used in the process conform to the standards. Carefully check the tools every 30-50 assemblies.
- Before fastening the components to the system onboard the machine, check the alignment between the tube and the fitting.
- Fittings must not be used to correct any misalignment or to support tubes.
- Long tubes or those liable to high stress must be clamped to avoid excessive vibrations. A poor alignment could damage the operation of the system.
- The proper lubrication of the components involved in the tightening is essential for good system operation. We advise the use of mineral oils or torquen tension for carbon steel fittings, consisting of anti-seizing compound (Nickel based), Chesterton or similar, for stainless steel fittings.
- The fittings and the valves in this technical catalogue may be used for fluid-dynamic connections only. Indicated pressures are for steel tubes only.
- Mixing carbon and stainless steel components is not allowed.
- Indicated pressures are for steel tubes only.

UTILISATION STANDARDS

CARBON STEEL FITTINGS

- High quality tubes must be employed to assure correct use and related technical performance of the carbon steel fitting. The use of tubes without the aforementioned characteristics may seriously impair the efficiency of the fitting. CAST S.p.A. recommends using the following tubes only: calibrated and polished, cold drawn seamless tubes, normalised with inert gas, in E235 material according to EN 10305-4 (ST 37.4 according to DIN 1630 I DIN 2391); the maximum permitted hardness, measured on the outer diameter of the tube, is 75 HRB.

STAINLESS STEEL FITTINGS

- High quality tubes must be employed to assure correct use and related technical performance of stainless steel fittings. The use of tubes without the aforementioned characteristics may seriously impair the efficiency of the fitting. CAST S.p.A. recommends using the following tubes only: calibrated and polished, cold drawn seamless tubes 1.4571 as per UNI EN 10216-5 or ASTM A 269; the maximum permitted hardness, measured on the outer diameter of the tube, is 85 HRB.

TIGHTENING TORQUES ON THE SWIVEL CONE

BS 5200 cone for carbon and stainless steel

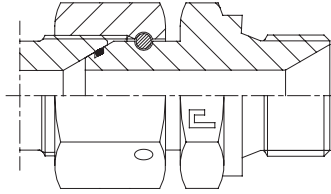

Series	Gas Thread	Torque (Nm) ^{+10%} / ₀	Metric Thread	Torque (Nm) ^{+10%} / ₀
UNIVERSAL	G 1/8	25	M12x1,5	35
	G 1/4	65	M14x1,5	45
	G 3/8	85	M16x1,5	55
	G 1/2	150	M18x1,5	70
	G 5/8	200	M20x1,5	80
	G 3/4	260	M22x1,5	100
	G 1	320	M26x1,5	170
	G 1 1/4	500	M30x1,5	250
	G 1 1/2	600		
	G 2	700		

Notes:

The values in the tightening tables are approximate and derive from practical tests run at the laboratory in Casalgrasso (CN), which may vary based on the materials and tolerances of the components used. Thus an awareness of the controls to be performed is required.

All the values expressed in Newton Meters (Nm) for the tightening torques on the BS 5200 swivel cone represent the torquing moment needed to obtain the correct tightness.

SAFETY FACTORS

The technical choice to use the wire, rather than the crimped fittings, is made in compliance with the highest safety standards. This prerogative is also confirmed by the use of stainless steel wire in the wiring of our products, which guarantees the safety of the product for a lot longer, also in the presence of a particularly aggressive microclimate.

EXAMPLE OF DESTRUCTIVE TESTING

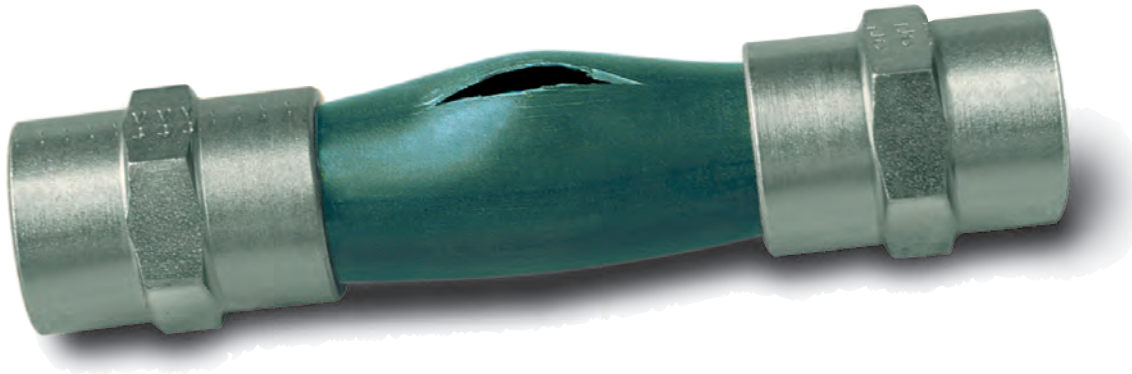

Destructive testing with 22x2 carbon steel tube
The tube burst at 800 bars without any leakage or sweating from the sealing points.