

Portable Minimes Pressure Testing Kits

Minimes[®] Digital Gauge Kit

- Test under pressure using leak-free Minimes connections up to 630 bar
- Everything you need to get two pressure readings
- Ultra low cost - ideal for OEM's
- Rugged, lightweight and portable



R & D

Mobile hydraulics

End of Line Testing

Plant maintenance

Industrial hydraulics

The Minimes digital gauge test point test kit is a light weight easy to use, all-in-one pressure test kit for fast and accurate pressure testing. With The kit comes with Minimes test points and test point adaptors offering a life time leak-free guarantee.

PORTABLE MINIMESS PRESSURE TESTING KITS

Minimess® Pressure Test Kit



WHATS INCLUDED IN THE DIGITAL PRESSURE GAUGE KIT?

- 1 x 75mm digital pressure gauge user selectable up to 600 bar with protective rubber cuff.
- 1 x Minimess® I620 test point - 1/4" BSP threaded.
- 1 x G1/4" BSP female to Minimess® I620 female direct gauge to test point adaptor.
- 1 x G1/4" BSP female to Minimess® I620 male direct gauge to hose adaptor.
- 1 x 630 bar rated Minimess® I620 pressure test hose with female ends- 1.5 meters long.
- Additional 3/8" & 1/2" BSP male threaded adaptors & seals.

KEY FEATURES

- Test under pressure using Hydrotechnik leak free minimess connections up to 630 bar.
- Everything you need to get an accurate pressure reading.
- Ultra low cost - ideal for OEM's.
- Lifetime leak free guarantee.

ORDER CODE

3103-81-X X.50

Replace X in above code with pressure gauges required from the following options:

04 = 0 to 60 bar

07 = 0 to 250 bar

09 = 0 to 600 bar

Kits with 2 x digital pressure gauges are also available (see next page) along with further technical data.

MINIMESS® - THE MARKET LEADER FOR TEST POINTS

Safe, easy to use, diverse, leak-free and long lasting.

Developed by Hydrotechnik more than 50 years ago, they are found worldwide in hydraulic, process and gas systems. Minimesse pressure test points offer the most advanced sealing system available with working pressures up to 630 bar. A life-time leak free guarantee and suitability with almost any fluid or gas makes Minimesse the most versatile test point available.

When installed in a live system Minimesse test points provide an ideal way to obtain random pressure or temperature checks during servicing or fault finding. Test hoses, gauges or sensors can be connected or disconnected under full system pressure without loss of system pressure, media loss or dirt ingress.



MINIMESS® - ONE PRODUCT - MANY APPLICATIONS

- Hydraulic testing
- Bleeding
- Filling
- Gas testing
- Oil sampling
- Gas charging
- Mobile hydraulics
- Industrial hydraulics
- Offshore & subsea
- Process plant
- Pneumatics
- Automotive



Digital pressure gauges



The ideal low cost solution to digital pressure testing. With display of pressure and pressure peaks, digital pressure gauges offer excellent accuracy and peak capture which a standard pressure gauge simply can not provide. The unit comes with a rotatable face for better reading. Simple operation via a 3 button panel. Min/Maximum values displayed with each test.

- Great Accuracy
- Easy to read
- Rotate display
- Easy to use
- Peak min/max storage
- Low cost

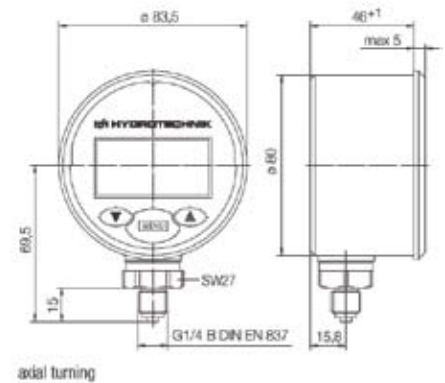

Technical data

Display:	4-digit, 7-segment LCD display, 11 mm height, additional bar graph with 10 segments scale
Accuracy:	$\pm 0.5\%$ of F.S. Conversion rate: 5/sec
Measuring range:	0 to 60 bar, 0 to 250 bar or 0 to 600 bar
Units:	MPa, PSI and bar
Overload limit:	Proof pressure, 2.0x, 1000 bar max
Pressure connection:	ISO 228-G 1/4
Wetted parts:	Stainless steel 1.4571
Power supply:	9 V monoblock battery, 5000 h
Protection type:	IP 65 accord. to EN 60529/IEC 529
Case:	Stainless steel
Weight:	0.4 kg

Options & Ordering Information

Pressure range Bar	Part number Brass
0 - 60	9801-99-00.60
0 - 250	9801-99-02.50
0 - 600	9801-99-06.00

MINIMESS®- digital pressure test kits

One or two digital pressure gauges with Minimesse test points, adaptors & hose in carry case



Single gauge kit Part codes

Pressure range Bar	Part number
0 - 60	3101-81-04.50
0 - 250	3101-81-07.50
0 - 600	3101-81-09.50

Double gauge kit Part codes

Pressure ranges Bar	Identification	Part number
0-60	4	3101 - 81 - X.X.50 Gauge 1 Gauge 2
0-250	6	
0-600	9	



INDUSTRIAL TEST & MEASUREMENT SOLUTIONS

Hydrotechnik UK Ltd is one of the UK's leading test and measurement equipment distributors and manufacturers, servicing a wide range of industries since 1990.

In addition to pressure sensors and instrumentation, Hydrotechnik has a large product portfolio featuring Minimes® test points & adaptors, high pressure microbore hose assemblies and Minimes® test kits for analogue testing, charging, bleeding or sampling of almost any fluid or gas.

We have extensive experience in the design, development, manufacture and commissioning of fluid power test rigs for end of production sign off or component testing. Our test rigs are used in demanding and 'mission critical' applications including defence, manufacturing quality control, plant maintenance and research and development. Users of Hydrotechnik test rigs rigorously test pumps, hydraulic hoses, moulded coolant hoses, pipes, manifolds, tanks, accumulators, valves and many other components to ensure they are fit for purpose.



Call us on 0800 068 4134 for more information and to obtain our other brochures:

