	<p>HySense QT 1xx</p>	
	<p>Präzise Messturbine mit Innengewinde-Anschluss nach DIN ISO 228, wahlweise erhältlich mit Frequenz (Rechtecksignal), analogem (4...20mA) oder CAN Ausgangssignal.</p> <ul style="list-style-type: none"> • Ansprechzeit <0.05 s • Geringer Durchflusswiderstand • Automatische Sensorerkennung ISDS 	<p><i>Precise measuring turbine with internal thread connection according to DIN ISO 228, available with frequency (square wave signal), analogue (4 ... 20mA) or CAN output.</i></p> <ul style="list-style-type: none"> • <i>Response time <0.05 s</i> • <i>Low flow resistance</i> • <i>Automatic sensor detection ISDS</i>
<p>Beschreibung <i>Description</i></p>	<p>Das Turbinenlaufrad wird durch die Strömungsenergie des durchströmenden Mediums in Rotation versetzt. Anhand der Frequenz des Turbinenlaufrades wird der vorhandene Volumenstrom ermittelt. Die Messturbinen sind werkseitig für Mineralöl bei 30mm²/s kalibriert, optional sind andere Kalibrierviskositäten möglich.</p> <p>In jedem Ausgangssignal ist die ISDS Funktionalität implementiert.</p>	<p>The turbine wheel is rotated by the flow energy of the medium. Based on the frequency of the turbine impeller the correct flow rate is determined. By default the turbines are measured and calibrated for mineral oil at 30mm²/s, optionally other calibration viscosities are possible.</p> <p><i>The ISDS functionality is implemented in each output signal.</i></p>
<p>Funktionsprinzip <i>Operating principle</i></p>	<p>Das Turbinenlaufrad wird durch die Strömungsenergie des durchströmenden Mediums in Rotation versetzt. Dabei ist die Laufradfrequenz annähernd proportional zur mittleren Strömungsgeschwindigkeit (über dem Rohrquerschnitt). Resultierend daraus ist der Volumenstrom ebenfalls annähernd proportional zur Laufradfrequenz. Diese wird durch einen externen Sensor detektiert, verarbeitet und ausgegeben.</p>	<p>The turbine wheel is set in rotation by the flow energy of the medium. The turbine frequency is approximately proportional to the flow velocities, resulting that the flow rate is also approximately proportional to the turbine frequency. This frequency is detected, processed and delivered by the pickup.</p>
<p>Verwendungszweck <i>Designated use</i></p>	<p>Zum Messen von Volumenstrom in stationären sowie mobilen Hydraulikanlagen. Verwendung in Hydraulik und der Ölindustrie mit Flüssigkeiten der Gruppe 2 gemäß Klassifizierung der Druckgeräterichtlinie 2014/68/EU (ungefährliche Fluide). Prädestiniert für Hydrauliköle sowie Öle auf Mineralölbasis, nicht für den Einsatz in Wasser oder Gasen geeignet.</p>	<p><i>For measuring flow rates instationary and mobile hydraulicsystems. Use in hydraulic and oil industry. Use only in liquids of group 2 according to the classification of the pressure equipment directive 2014/68/EU (non-dangerous fluids). Predestinated for hydraulic oils and mineral oil based liquids, not suitable for water or gases</i></p>

<p>Gebrauchshinweise <i>Note for use</i></p>	<ul style="list-style-type: none"> • Jegliche Anwendung außerhalb der technischen Spezifikationen sind nicht zulässig • Nicht mit Wasser, Luft oder Gasen verwenden • Es dürfen sich keine Luftblasen im Hydrauliksystem befinden • Druckschläge vermeiden • Schnellen Richtungswechsel des Messmediums vermeiden • Nicht mit Pressluft ausblasen • Am Turbinenausgang muss der relative Systemdruck ≥ 1 bar sein • Viskositätsabweichung von der Kalibrierviskosität verschlechtert die Messgenauigkeit deutlich 	<ul style="list-style-type: none"> • <i>Any application out of the technical specification aren't allowed</i> • <i>Do not use with water, air or gas</i> • <i>No air bubbles in the hydraulic system</i> • <i>Avoid pressure shocks</i> • <i>Avoid rapid changes in direction of the medium</i> • <i>Don't clean with compressed air</i> • <i>The relative system pressure must be ≥ 14.5 psi in the turbineflow meter output</i> • <i>Viscosity deviation from the calibration viscosity reduce the measurement accuracy significantly</i>
---	---	---

<p>Hinweise zur Produktauswahl <i>Note for product choice</i></p>	<p>Für einen sicheren und störungsfreien Betrieb der Volumensensoren ist die richtige Auswahl von Typ und Baugröße entscheidend. Aufgrund verschiedener Anwendungen und Sensorausführungen sind die technischen Daten im Datenblatt allgemeiner Art. Bestimmte Eigenschaften der Geräte sind abhängig von Typ, Baugröße und Messbereich sowie vom Messmedium. Für eine exakte Auswahl setzen sie sich bitte mit Ihrem Kundenberater in Verbindung.</p>	<p>For a safe and trouble-free operation of the turbine flow meter is the correct selection of type and size fundamental. The technical data sheet is given in general nature. Certain properties of the devices depend on type, size and range, as well as of the measured liquid. For an accurate selection, please contact your customer consultant</p>
--	--	--

<p>Hinweis zum Datenblatt <i>Notes to data sheet</i></p>	<p>Teil 1 dieses Datenblatts enthält Angaben, die für die gesamte Produktreihe HySense QT 1xx zutreffen. Teil 2 listet die für das jeweilige Ausgangssignal gültigen Eigenschaften auf.</p>	<p>Part 1 of the data sheet includes common technical data for the complete HySense QT 1xx series. Finally, part 2 lists the parameters for different output signals..</p>
---	---	--

Teil 1 **Allgemeine Angaben zur Produktserie**
Part 1 **Common features for the product series**

<p>Eigenschaften <i>Properties</i></p>			
Parameter	Größe <i>Dimensions</i>	Einheit <i>Units</i>	Bemerkung <i>Remarks</i>
Anprechzeit <i>Response time</i>	< 0.05	s	
Viskositätsbereich <i>Viscosity range</i>	1...100	cSt	Höhere Viskositäten auf Anfrage <i>Higher viscosities on request</i>

Parameter	Größe Dimensions	Einheit Units	Bemerkung Remarks
Standard Kalibrierviskosität <i>Standard calibration viscosity</i>	0	cSt	
Mediumtemperatur <i>Medium temperature</i>	-20...85 -4...185	°C °F	
Umgebungstemperatur <i>Ambient temperature</i>	-20...85 -4...185	°C °F	
Lagertemperatur <i>Storage temperature</i>	-20...85 -4...185	°C °F	
Turbinengehäuse <i>Turbine housing</i>	Aluminiumlegierung anodisiert Aluminium alloy anodized	EN AW 7075 / DIN 30645	
Aufnehmergehäuse <i>Sensor housing</i>	Aluminiumlegierung anodisiert Aluminium alloy anodized	EN AW 2007 / DIN 30645	
Dichtungsmaterial <i>Sealing material</i>	FKM/EPDM	Andere auf Anfrage <i>Others on request</i>	
Medienverträglichkeit <i>Fluid compatibility</i>	Hydrauliköle, Öle auf Mineralölbasis <i>Hydraulic oils, mineral oil based fluids</i>	Andere auf Anfrage <i>Others on request</i>	
IP-Schutz <i>Protection</i>	IP 67	Gilt für alle Aufnehmer <i>Applies to all Pick-Ups</i>	
Vibrationsfestigkeit <i>Vibration resistance</i>	10G (5...2000Hz)	IEC 60068-2-6	
Schockfestigkeit <i>Shock resistance</i>	50G (11ms)	IEC 60068-2-29	

Baugruppen-Zeichnung
Assembly drawing

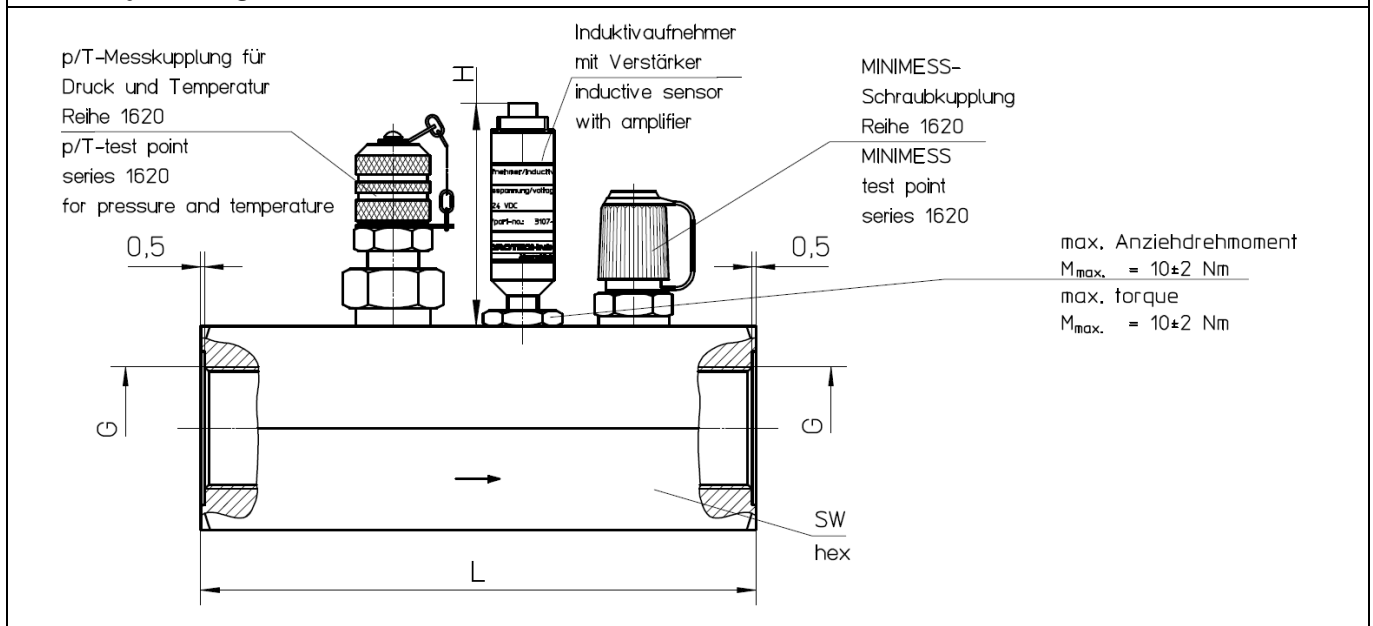

Baugröße und Eigenschaften Design size and specifications						
ISO 228 [L/min]						
Baugröße Size	Anschlussgewinde Connection size	Max. Druck Max. pressure		Gewicht Weight	SW Hex	Länge Length
	[ISO 228]	[bar]	[psi]	[g]	[mm]	[mm]
QT 1xx 10 L/min	G1/4	420	6000	ca. 685	41	120

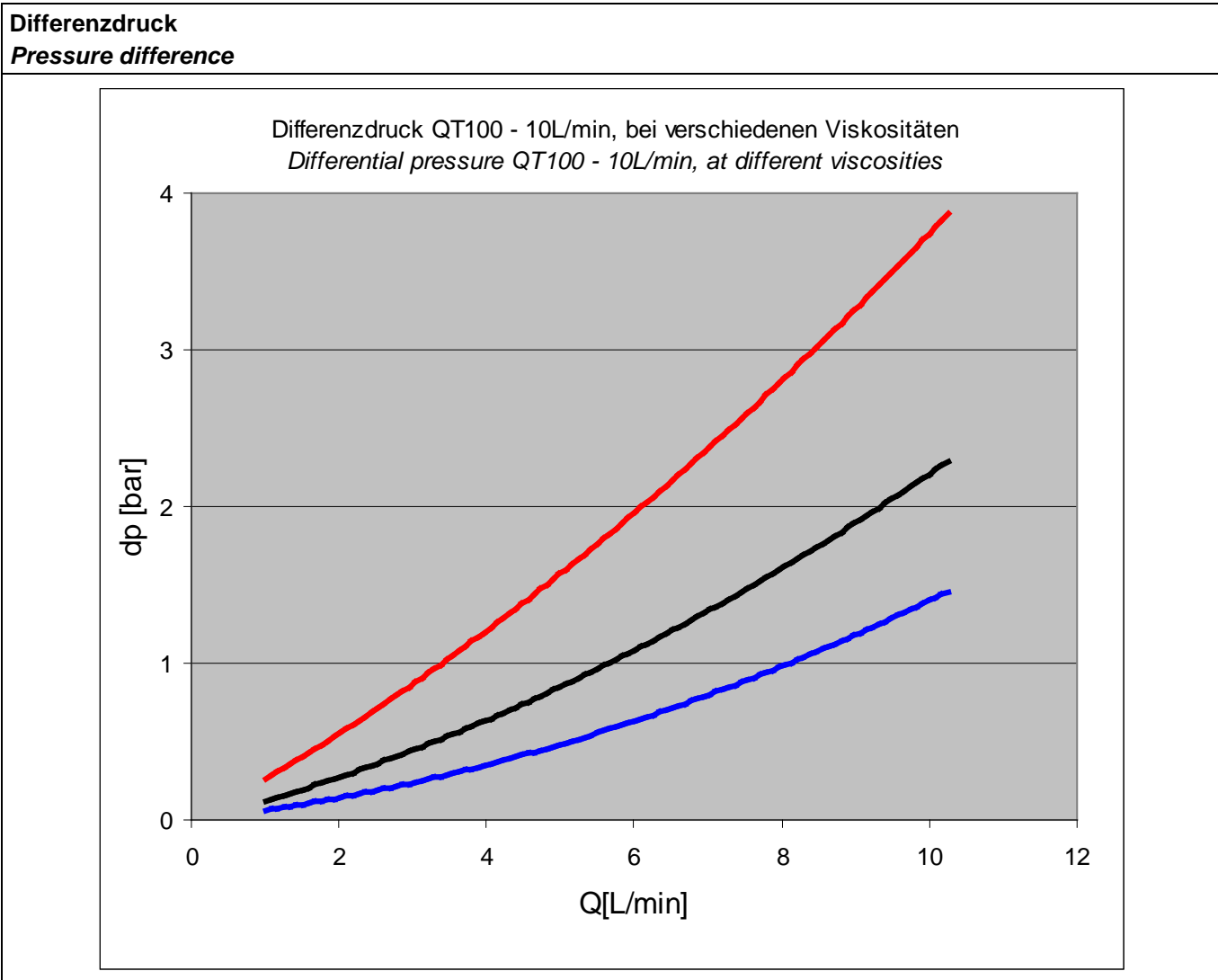

Sensorhöhe <i>sensor height</i>			
Baugröße <i>Design size</i>	QT 100	QT 106	QT 110
	[mm]	[mm]	[mm]
QT 1xx 10L/min	62	98	

Einbauhinweise <i>Installation instructions</i>	<ul style="list-style-type: none"> • Einbaulage beliebig, standardmäßige Strömung in Pfeilrichtung • Vor dem Einbau Anlage von Verunreinigungen befreien • Keine Schmutzpartikel >25µm im Messfluid • Nach dem Einbau langsam mit Betriebsmittel füllen und Leitungen entlüften • Starke Querschnittsänderungen in der Einlaufstrecke vermeiden • Empfohlene gerade Einlaufstrecke vor der Messturbine ist 30 x Nenndurchmesser <p>Empfohlene Auslaufstrecke nach der Messturbine ist 10 x Nenndurchmesser</p>	<ul style="list-style-type: none"> • <i>Any mounting position possible, standard flow in direction of arrow</i> • <i>Before mounting, clean the system by thoroughly rinsing of contaminants</i> • <i>No particles > 25µm in the fluid</i> • <i>After mounting, please fill slowly with the operating medium and vent the pipes</i> • <i>Avoid strong cross-sectional changes in the inlet zone</i> • <i>Recommended straight inlet zone of the turbine is 30 x nominal diameter</i> • <i>Recommended outlet zone of the turbine is 10 x nominal diameter</i>
	Anzugsmomente (Toleranz +10%, Edelstahlgewinde schmieren) <i>Recommended tightening torque (tolerance +10%, thread lubricated)</i>	
	ISO 228-G1/4	75 Nm
	ISO 228-G3/4	155 Nm
	ISO 228-G1	265 Nm
	ISO 228-G1 1/4	385 Nm
	MINIMESS® ISO228-G 1/4 <i>Torque MINIMESS®ISO228-G 1/4</i>	40 Nm
	MINIMESS® 7/16-20 UNF (ANSI B1.1) <i>Torque MINIMESS®7/16-20 UNF (ANSI B1.1)</i>	30 Nm
Signalaufnehmer <i>Torque sensor nut</i>	10 Nm	

Typenschlüssel für Turbinen Volumendurchflusssensoren QT 5xx
Type code for turbine flow meter QT 5xx

Bestellbeispiel:

How to order:

3	1	V	C	-	72	-	3	5	.	030	
Messgeräte / Sensorik allgemein / Instruments / Sensors general	Medienverträglichkeit / Medium compatibility	Aufnehmer / sensor	Serie / series	Anschlussgewinde / Durchflussbereich connecting thread / flow range	01	ISO 228-G $\frac{1}{4}$ *	3	5	.	Kalibrierviskosität calibration viscosity	
										010	10cSt
										030	30cSt* (Standardkalibrierung)
										046	46cSt
										xxx	xxxcSt (auf Anfrage / on request)
										5	p/T-Messkupplung Reihe 1620 (Kennzahl 04)*
										6	p/T-Messkupplung Reihe 1615 (Kennzahl 04)
										2	Schraubkupplung Reihe 1615, Kunststoffkappe
										3	Schraubkupplung Reihe 1620, Kunststoffkappe*
										3	1
3	1	V	C	-	72	-	3	5	.	030	

*Standard

Typenschild (exemplarisch)
Type plate (example)

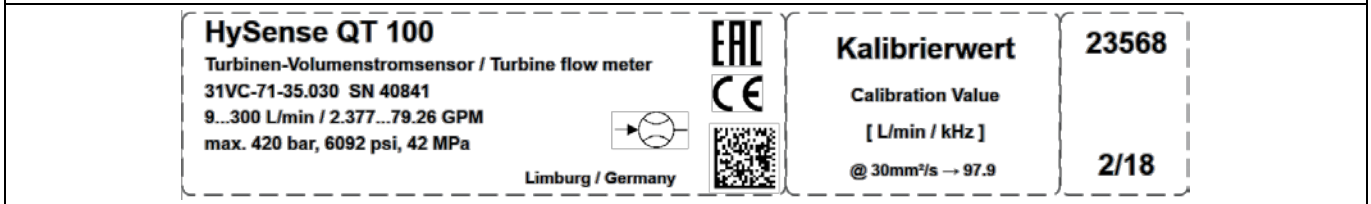

TKZ Order number	Zubehör und Ersatzteile Accessories and spare parts
8824-S1-xx.xxS ¹	Messkabel, Frequenz, 4...20mA, M16 6-pol. Stecker – M16 6-pol. Buchse <i>measuring cable frequency, 4...20mA, M16 6-pole connector – 6-pole M16 socket</i>
8824-S1-xx.xxH ¹	Messkabel, Frequenz, 4...20mA, ISDS, M16 6-pol. Stecker – M16 6-pol. Buchse (High End) <i>measuring cable frequency, 4...20mA, M16 6-pole connector – 6-pole M16 socket (High End)</i>
8824-S6-xx.xxS ¹	Messkabel, Frequenz, 4...20mA, M16 6-pol. Stecker – offenes Kabelende <i>measuring cable frequency, 4...20mA, M16 6-pole connector – open cable end</i>
8824-S6-xx.xxH ¹	Messkabel, Frequenz, 4...20mA, ISDS, M16 6-pol. Stecker – offenes Kabelende (High End) <i>measuring cable frequency, 4...20mA, M16 6-pole connector – open cable end (High End)</i>
8824-S2-xx.xxS ²	Adapterkabel, Frequenz, 4...20mA, M16 5-pol. Stecker – M16 6-pol. Buchse <i>adapter cable frequency, 4...20mA, M16 5-pole connector – 6-pole M16 socket</i>
8824-S2-xx.xxH ²	Adapterkabel, Frequenz, 4...20mA, ISDS, M16 5-pol. Stecker – M16 6-pol. Buchse (High End) <i>adapter cable frequency, 4...20mA, M16 5-pole connector – 6-pole M16 socket (High End)</i>
8824-S3-xx.xxS ³	Verlängerungskabel, Frequenz, 4...20mA, M16 6-pol. Stecker – M16 6-pol. Buchse <i>extension cable frequency, 4...20mA, M16 6-pole connector – 6-pole M16 socket</i>
8824-S3-xx.xxH ³	Verlängerungskabel, Frequenz, 4...20mA, M16 6-pol. Stecker – M16 6-pol. Buchse (High End) <i>extension cable frequency, 4...20mA, M16 6-pole connector – 6-pole M16 socket (High End)</i>
8824-S4-xx.xxS ⁴	Messkabel Doppelsignalabgriff bei Frequenzeingang <i>measuring cable double signal connection for frequency output</i>
8824-M8-xx.xx ⁵	Messkabel CAN, M12 5-pol. Buchse – offenes Kabelende <i>measuring cable CAN for MS 5060, M12 5-pole socket – open cable end</i>
8824-R7-02.50	Messkabel CAN für MS 4010 und MS 5060plus / M12 5-pol. Buchse – M12 8-pol. Stecker <i>measuring cable CAN for MS 4010 and 5060plus / M12 5-pole socket – M12 8-pole connector</i>
8824-M5-02.50	Messkabel CAN für MS 5060, M12 5-pol. Buchse – M12 8-pol. Stecker <i>measuring cable CAN for MS 5060, M12 5-pole socket – M12 8-pole connector</i>
8824-V1-02.50	Messkabel, Frequenz, 4...20mA, M12 4-pol. Stecker – offenes Kabelende <i>measuring cable frequency, 4...20mA, M12 4-pole connector – open cable end</i>

¹ Verfügbare Standardlängen: 02.50 = 2,5m; 05.00 = 5,0m; 10.00 = 10,0m. Available standard lengths: 02.50 = 2,5m; 05.00 = 5,0m; 10.00 = 10,0m.

² Verfügbare Standardlängen: 00.30 = 0,3m; 02.50 = 2,5m; 05.00 = 5,0m; 10.00 = 10,0m. Available standard lengths: 00.30 = 0,3m; 02.50 = 2,5m; 05.00 = 5,0m; 10.00 = 10,0m.

³ Verfügbare Standardlängen: 10.00 = 10,0m; 20.00 = 20,0m. Available standard lengths: 10.00 = 10,0m; 20.00 = 20,0m.

⁴ Verfügbare Standardlängen: 00.20 = 0,2m; 00.50 = 0,5m. Available standard lengths: 00.20 = 0,2m; 00.50 = 0,5m.

⁵ Verfügbare Standardlängen: 05.00 = 5,0m; 10.00 = 10,0m. Available standard lengths: 05.00 = 5,0m; 10.00 = 10,0m.

TKZ Order number	Zubehör und Ersatzteile Accessories and spare parts
8824-V3-02.50H	Messkabel, Frequenz, 4...20mA, M12 4-pol. Stecker – offenes Kabelende (High End) <i>measuring cable frequency, 4...20mA, M12 4-pole connector – open cable end (High End)</i>
2149-04-15.53N	p/T MINIMESS®-Testpunkt (FKM), ISO 228 G1/4" <i>p/T MINIMESS®-test point (FKM), ISO 228 G1/4"</i>
2103-30-18.10N	p MINIMESS®-Testpunkt (FKM), ISO 228 G1/4" <i>p MINIMESS®-Testpunkt (FKM), ISO 228 G1/4"</i>
34P3-15-S-01.37A2	HySense PR 400, 4...20mA, IP67, 0...40 MPa / Drucksensor <i>HySense PR 400, 4...20mA, IP67, 0...40 MPa / pressure sensor</i>
3969-04-S-01.00S	HySense TE 110, 4...20mA, IP64, -50...200 °C / Temperatursensor <i>HySense TE 110, 4...20mA, IP64, -50...200 °C / temperature sensor</i>
3763-03-34.00	HySense TP 180, 4...20mA, IP40, 0...60 MPa / Druck- / Temperatursensor <i>HySense TP 180, 4...20mA, IP40, 0...60 MPa / pressure / temperature sensor</i>
3410-1600-A233F03	HySense RS 500, Frequenz, M16 6-pol. Stecker <i>HySense RS 500, frequency, M16 6-pol. connector</i>
3410-1600-A211F07	HySense RS 500, Frequenz, M12 4-pol. Stecker <i>HySense RS 500, frequency, M12 4-pol. connector</i>
3410-1400-A133Z1S	HySense RS 510, analog 4...20mA, M16 6-pol. Stecker <i>HySense RS 510, analog 4...20mA, M16 6-pol. connector</i>
3410-1400-A233Z1S	HySense RS 510, analog 4...20mA, M12 4-pol. Stecker <i>HySense RS 510, analog 4...20mA, M12 4-pol. connector</i>
3410-1400-A213C11	HySense RS 506, CAN, M12 5-pol. Stecker <i>HySense RS 506, CAN, M12 5-pol. connector</i>

Rekalibrierung von Volumendurchflusssensoren *Recalibration from flow sensors*

Jeder Turbinen Durchflusssensor besitzt seine individuelle Messcharakteristik, welche selbst bei gleichen Sensortypen sowie -größen variiert. Grund hierfür sind die mechanischen Fertigungstoleranzen, welche bei dynamischen Präzisionssensoren massiven Einfluss auf die Messcharakteristik haben. Resultierend daraus muss jeder neue Sensor kalibriert und justiert werden, um eine spezifizierete Messperformance sicherzustellen. Wird ein Sensor im Feld betrieben, erfolgt in Abhängigkeit der Betriebsart und der Betriebsbedingungen eine zeitliche Änderung der Messcharakteristik. Diese Veränderung resultiert aus Überlastbetrieb, Ablagerungen, Kontaminierung, Alterung sowie Änderung der Medieneigenschaften. Die Veränderung der Messcharakteristik kann sich negativ auf die Messperformance auswirken. Dies kann nicht im Vorfeld prognostiziert werden und ist vom Einsatz abhängig. Infolgedessen sollte jeder Sensor in bestimmten Intervallen recalibriert werden, um diese Veränderung festzustellen und ggf. zu kompensieren. Wir empfehlen die folgenden Intervalle. Liegen jedoch empirische Daten vor, sollte die Definition auf dieser Basis getroffen werden.

Each turbine flow sensor has an own measuring characteristic, which varies even with the same sensor type and sizes. The reason for this difference is the mechanical manufacturing tolerances, which have a major influence on the measurement characteristic. Each new sensor must be calibrated and adjusted to ensure the specified measurement performance. If a sensor is operated in the field, a temporal change in the measurement characteristics occurs depending on the operating mode and the operating conditions. This change results from overload operation, deposits, contamination, aging and changes in media properties. The change in the measurement characteristics can have a negative effect on the measurement performance. This can't be predicted in advance and depends on the deployment. As a result, each sensor should be recalibrated at certain intervals in order to detect and, if necessary, compensate for this change. We recommend the following intervals. If empirical data are available, the definition should be made on this basis.

Rekalibrierung von Volumendurchflusssensoren <i>Recalibration from flow sensors</i>	
<ul style="list-style-type: none"> • Laboreinsatz (temp. Einsatz als Mastergeber mit geringer Einsatzdauer) → 36 Monate • Standardgebrauch (temp. Einsatz bei Teillast) → 24 Monate • Erhöhte Belastung (station. Einsatz bei Teillast) → 12 Monate • Extreme Belastung (station. Einsatz bei Vollast) → 6 Monate 	<ul style="list-style-type: none"> • <i>Laboratory application (temporary use as a master encoder with a short operating time)</i> → 36 months • <i>Standard use (temporary use with partial load)</i> → 24 months • <i>Increased load (stationary use with partial load)</i> → 12 months • <i>Extreme load (steady load at full load)</i> → 6 months

Umrechnung, Durchfluss ↔ Strom <i>Conversion, flow rate ↔ current</i>	
Durchfluss → Strom <i>flow rate → current</i>	Strom → Durchfluss <i>current → flow rate</i>
$I(Q_{\text{read}}) = \frac{16 \text{ mA} \cdot Q_{\text{read}}}{Q_{\text{max}}} + 4 \text{ mA}$	$Q(I_{\text{read}}) = \frac{Q_{\text{max}} \cdot (I_{\text{read}} - 4 \text{ mA})}{16 \text{ mA}}$

Europäische Konformität <i>European Conformity</i>		
Elektromagnetische Verträglichkeit / <i>electromagnetic compatibility</i>	Richtlinie 2004/108/EG	Directive 2004/108/EG
Druckgeräte / <i>pressure equipment</i>	Richtlinie 2014/68/EU	Directive 2014/68/EU

REACH-Regulation (EU) No.1907/2006, Art. 33	Die HYDROTECHNIK GmbH ist als Hersteller von Erzeugnissen, im Sinne der REACH-Verordnung, nachgeschalteter Anwender geringer Mengen und somit nicht registrierungspflichtig. Wir liefern ausschließlich nicht chemische Produkte (Erzeugnisse). Diese beinhalten keine Stoffe, die nach REACH Artikel 7 unter normalen oder vernünftigerweise vorhersehbaren Verwendungsbedingungen zur Freisetzung beabsichtigt sind.	<i>HYDROTECHNIK GmbH as a manufacturer of products is, with regard to the REACH regulation, a downstream-user of small quantities. As such it is not obliged to register. We exclusively supply non-chemical products. These do not contain substances which, according to REACH Article 7, are intended for release under normal or reasonably foreseeable conditions of use.</i>
--	--	--

Haftungsausschuss Limitation of Liability	Hydrotechnik behält sich Änderungen an diesem Dokument vor, ohne vorherige Information. Im Zweifelsfall gilt die deutsche Sprachversion. Angaben in Klammern dienen nur zur Information.	<i>Hydrotechnik reserves the right to modify this document without prior notice. The German language version is valid in any case of doubt. Data in brackets only given for information.</i>
--	--	--

Teil 2 **Eigenschaften nach Ausgangssignall**
Part 2 **Parameters for output signal**

Frequenz

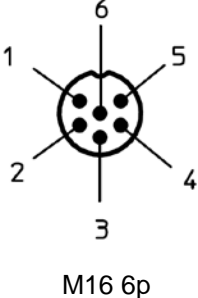
Pinbelegungen <i>Pin assignments</i>	Bezeichnung <i>Labeling</i>	Nr. <i>No</i>	Funktion	<i>Function</i>
Rundsteckverbinder M16 x 0.75 mit Schraubverriegelung, Ausführung 06-a, 6-polig, Stecker <i>Circular connectors M16 x 0.75 with screw-locking Layout 06-a, 6 poles, male IEC / DIN EN 61076-2-106</i>				
	QT 100 Frequenz / Frequency			
	f-Signal	1	Frequenzsignal	<i>Frequency signal</i>
	GND	2	Masse	<i>Ground</i>
	+Ub	3	Versorgungsspannung	<i>Supply voltage</i>
	NC	4	nicht verbunden	<i>not connected</i>
	NC	5	nicht verbunden	<i>not connected</i>
	ISDS	6	Sensorerkennung	<i>Sensor detection</i>

Messgenauigkeit mit ISDS oder Linearisierung
Accuracy with ISDS or linearisation

Kalibrierter Bereich <i>Calibrated range</i>				Messgenauigkeit <i>Accuracy</i>
L/min		GPM		%
1	10	0.26	2.6	± 0.5 vom Messwert / <i>of reading</i>

Messgenauigkeit ohne Linearisierung
Accuracy without linearisation

Kalibrierter Bereich <i>Calibrated range</i>				Messgenauigkeit <i>Accuracy</i>
L/min		GPM		%
1	10	0.26	2.6	± 2.5 vom Messwert / <i>of reading</i>

CAN

Pinbelegungen <i>Pin assignments</i>	Bezeichnung <i>Labeling</i>	Nr. <i>No</i>	Funktion	<i>Function</i>
Rundsteckverbinder M12 x 1 mit Schraubverriegelung A-Kodierung, 5-polig, Stecker IEC / DIN EN 61076-2-101 <i>Circular connectors M12 x 1 with screw-locking A-coding, 5 poles, male IEC / DIN EN 61076-2-101</i>				
	QT 106 CAN			
	CAN SHLD	1	CAN Schirm	<i>CAN Shield</i>
	CAN V+	2	CAN Versorgung	<i>CAN Supply</i>
	CAN GND	3	CAN Masse	<i>CAN Ground</i>
	CAN H	4	CAN High	<i>CAN High</i>
	CAN L	5	CAN Low	<i>CAN Low</i>

Messgenauigkeit <i>Accuracy</i>				
Kalibrierter Bereich <i>Calibrated range</i>				Messgenauigkeit <i>Accuracy</i>
L/min		GPM		%
1	10	0.26	2.6	± 0.5 vom Messwert / <i>of reading</i>

CANopen Parameter					
Übertragungsrate / <i>transfer rate</i>	20		1000	kBit/s	
PDO / <i>process data object</i>		1			
Knoten Nr. / <i>Node Id.</i>		10			(hex = 0x0A)
COB ID PDO1		394			(hex = 0x18A)
Senderate / <i>sending rate</i>	10		1000	ms	
Geräte Status / <i>node state</i>		pre-operational			
Prozessdaten: <i>process data</i>					
Frequenz / <i>frequency</i>		fx1000		Hz	
Signaltyp / <i>value type</i>		ulong		Bytes	Byte [0...3]
Beispiel / <i>example</i>					1kHz => 0x000F4240
Volumenstrom / <i>flow rate</i>		Qx1000		l/min	alternativ gal / min
Signaltyp / <i>value type</i>		ulong		Bytes	Byte [4...7]
Beispiel / <i>example</i>					200l/min => 0x00030D40

Analog 4...20mA

Pinbelegungen <i>Pin assignments</i>	Bezeichnung <i>Labeling</i>	Nr. <i>No</i>	Funktion	<i>Function</i>
Rundsteckverbinder M16 x 0.75 mit Schraubverriegelung, Ausführung 06-a, 6-polig, Stecker <i>Circular connectors M16 x 0.75 with screw-locking Layout 06-a, 6 poles, male IEC / DIN EN 61076-2-106</i>				
<p>M16 6p</p>	QT 110 4...20 mA 2-Draht / 2-wire			
	Signal	1	Signal	<i>Signal</i>
	ISDS GND ⁶	2	Masse	<i>Ground</i>
	+Ub	3	Versorgungsspannung	<i>Supply voltage</i>
	NC	4	nicht verbunden	<i>not connected</i>
	NC	5	nicht verbunden	<i>not connected</i>
	ISDS	6	Sensorerkennung	<i>Sensor detection</i>

Messgenauigkeit <i>Accuracy</i>				
Kalibrierter Bereich <i>Calibrated range</i>				Messgenauigkeit <i>Accuracy</i>
L/min		GPM		%
1	10	0.26	2.6	± 0.5 vom Messwert / <i>of reading</i> zzgl. / <i>plus</i> ±0.1 vom Endwert / <i>of full scale</i>

Revision	Rev 00	Rev 01	Rev 02	Rev 03	Rev 04	Rev 05	Rev 06	Rev 07
	2018-01-29							
	MH							

⁶ Der Masse-Anschluss bei QT110 bezieht sich ausschließlich auf die ISDS-Kommunikation.
Ground pin of QT110 referring to ISDS communication exclusively.