	<p><b>HySense QT 3xx</b></p> <p>Präzise Messturbinen mit 2"-SAE Flanschanschluss, wahlweise erhältlich mit Frequenz (Rechtecksignal), analogem (4...20mA) oder CAN Ausgangssignal.</p> <ul style="list-style-type: none"> <li>• Ansprechzeit &lt;0.05 s</li> <li>• Automatische Sensorerkennung ISDS</li> <li>• Geringer Durchflusswiderstand</li> </ul>	<p><i>Precise measuring turbine with 2"-SAE flange connection, available with frequency (square wave signal), analogue (4 ... 20mA) or CAN output.</i></p> <ul style="list-style-type: none"> <li>• <i>Response time &lt;0.05 s</i></li> <li>• <i>Automatic sensor detection ISDS</i></li> <li>• <i>Low flow resistance</i></li> </ul>
<p><b>Beschreibung</b> <i>Description</i></p>	<p>Das Turbinenlaufrad wird durch die Strömungsenergie des durchströmenden Mediums in Rotation versetzt. Anhand der Frequenz des Turbinenlaufrades wird der vorhandene Volumenstrom ermittelt. Die Messturbinen sind werkseitig für Mineralöl bei 30mm<sup>2</sup>/s kalibriert, optional sind andere Kalibrierviskositäten möglich.</p> <p>In jedem Ausgangssignal ist die ISDS Funktionalität implementiert.</p>	<p><i>The turbine wheel is rotated by the flow energy of the medium. Based on the frequency of the turbine impeller the correct flow rate is determined. By default the turbines are measured and calibrated for mineral oil at 30mm<sup>2</sup>/s, optionally other calibration viscosities are possible.</i></p> <p><i>The ISDS functionality is implemented in each output signal.</i></p>
<p><b>Funktionsprinzip</b> <i>Operating principle</i></p>	<p>Das Turbinenlaufrad wird durch die Strömungsenergie des durchströmenden Mediums in Rotation versetzt. Dabei ist die Laufradfrequenz annähernd proportional zur mittleren Strömungsgeschwindigkeit (über dem Rohrquerschnitt). Resultierend daraus ist der Volumenstrom ebenfalls annähernd proportional zur Laufradfrequenz. Diese wird durch einen externen Sensor detektiert, verarbeitet und ausgegeben.</p>	<p><i>The turbine wheel is set in rotation by the flow energy of the medium. The turbine frequency is approximately proportional to the flow velocities, resulting that the flow rate is also approximately proportional to the turbine frequency. This frequency is detected, processed and delivered by the pickup.</i></p>
<p><b>Verwendungszweck</b> <i>Designated use</i></p>	<p>Zum Messen von Volumenströmen in stationären sowie mobilen Hydraulik-anlagen. In Verwendung mit Hydraulikölen und sonstigen Ölen auf Mineralölbasis.</p>	<p><i>For measuring flow rates in stationary and mobile hydraulic systems. In use with hydraulic oils and other mineral based oils.</i></p>
<p><b>Gebrauchshinweise</b> <i>Note for use</i></p>	<ul style="list-style-type: none"> <li>• Jegliche Anwendung außerhalb der technischen Eigenschaften ist zu vermeiden</li> <li>• Nicht mit Luft oder Gasen als Messmedium verwenden</li> <li>• Es dürfen sich keine Luftblasen im Hydrauliksystem befinden</li> </ul>	<ul style="list-style-type: none"> <li>• <i>Avoid any application outside of technical properties</i></li> <li>• <i>Do not use with air or gas as the measuring medium</i></li> <li>• <i>There must be no air bubbles in the hydraulic system</i></li> </ul>

<b>Gebrauchshinweise</b> <i>Note for use</i>	<ul style="list-style-type: none"> <li>• Druckschläge auf die Turbine Volumenstromsensor vermeiden</li> <li>• Schnellen Richtungswechsel des Messmediums vermeiden</li> <li>• Nicht mit Pressluft ausblasen</li> </ul>	<ul style="list-style-type: none"> <li>• <i>Avoid pressure shocks to the turbine flow meter</i></li> <li>• <i>Avoid rapid changes in direction of the medium</i></li> <li>• <i>Don't clean with compressed air</i></li> </ul>
---	--	---

<b>Hinweise zur Produktauswahl</b> <i>Note for product choice</i>	<p>Für einen sicheren und störungsfreien Betrieb der Volumensensoren ist die richtige Auswahl von Typ und Baugröße entscheidend. Aufgrund verschiedener Anwendungen und Sensorausführungen sind die technischen Daten im Datenblatt allgemeiner Art. Bestimmte Eigenschaften der Geräte sind abhängig von Typ, Baugröße und Messbereich sowie vom Messmedium. Für eine exakte Auswahl setzen sie sich bitte mit Ihrem Kundenberater in Verbindung.</p>	<p><i>For a safe and trouble-free operation of the turbine flow meter is the correct selection of type and size fundamental. The technical data sheet is given in general nature. Certain properties of the devices depend on type, size and range, as well as of the measured liquid. For an accurate selection, please contact your customer consultant</i></p>
--	--	---

<b>Hinweis zum Datenblatt</b> <i>Notes to data sheet</i>	<p>Teil 1 dieses Datenblatts enthält Angaben, die für die gesamte Produktreihe HySense QT 3xx zutreffen. Teil 2 listet die für das jeweilige Ausgangssignal gültigen Eigenschaften auf.</p>	<p><i>Part 1 of the data sheet includes common technical data for the complete HySense QT 3xx series. Finally, part 2 lists the parameters for different output signals..</i></p>
---	---	---

**Teil 1** **Allgemeine Angaben zur Produktserie**  
**Part 1** **Common features for the product series**

<b>Eigenschaften</b> <i>Properties</i>			
Parameter	Größe <i>Dimensions</i>	Einheit <i>Units</i>	Bemerkung <i>Remarks</i>
Ansprechzeit <i>Response time</i>	< 0.05	s	
Viskositätsbereich <i>Viscosity range</i>	1...100	cSt	höhere Viskositäten mit Einschränkungen auf Anfrage <i>higher viscosities with restrictions on request</i>
Standard Kalibrierviskosität <i>Standard calibration viscosity</i>	30	cSt	
Mediumtemperatur <i>Medium temperature</i>	-20...100 -4...185	°C °F	
Umgebungstemperatur <i>Ambient temperature</i>	-20...85 -4...185	°C °F	
Lagertemperatur <i>Storage temperature</i>	-20...85 -4...185	°C °F	

Parameter	Größe Dimensions	Bemerkung Remarks
Turbinengehäuse <i>Turbine housing</i>	Edelstahl passiviert Stainless steel passivated	DIN EN 2516
Aufnehmergehäuse Sensor housing	Aluminiumlegierung anodisiert Aluminium alloy anodized	EN AW 2007 / DIN 30645
Turbinenrad <i>Turbine wheel</i>	Automatenstahl / <i>machining steel</i>	1...10 L/min Andere / <i>others</i>
Dichtungsmaterial <i>Sealing material</i>	FKM	Andere auf Anfrage <i>Others on request</i>
Medienverträglichkeit <i>Fluid compatibility</i>	Hydrauliköle, Öle auf Mineralölbasis <i>Hydraulic oils, mineral oil based fluids</i>	Andere auf Anfrage <i>Others on request</i>
IP-Schutz <i>Protection</i>	IP 67	Gilt für alle Aufnehmer <i>Applies to all Pick-Ups</i>

**Baugruppen-Zeichnung**  
**Assembly drawing**

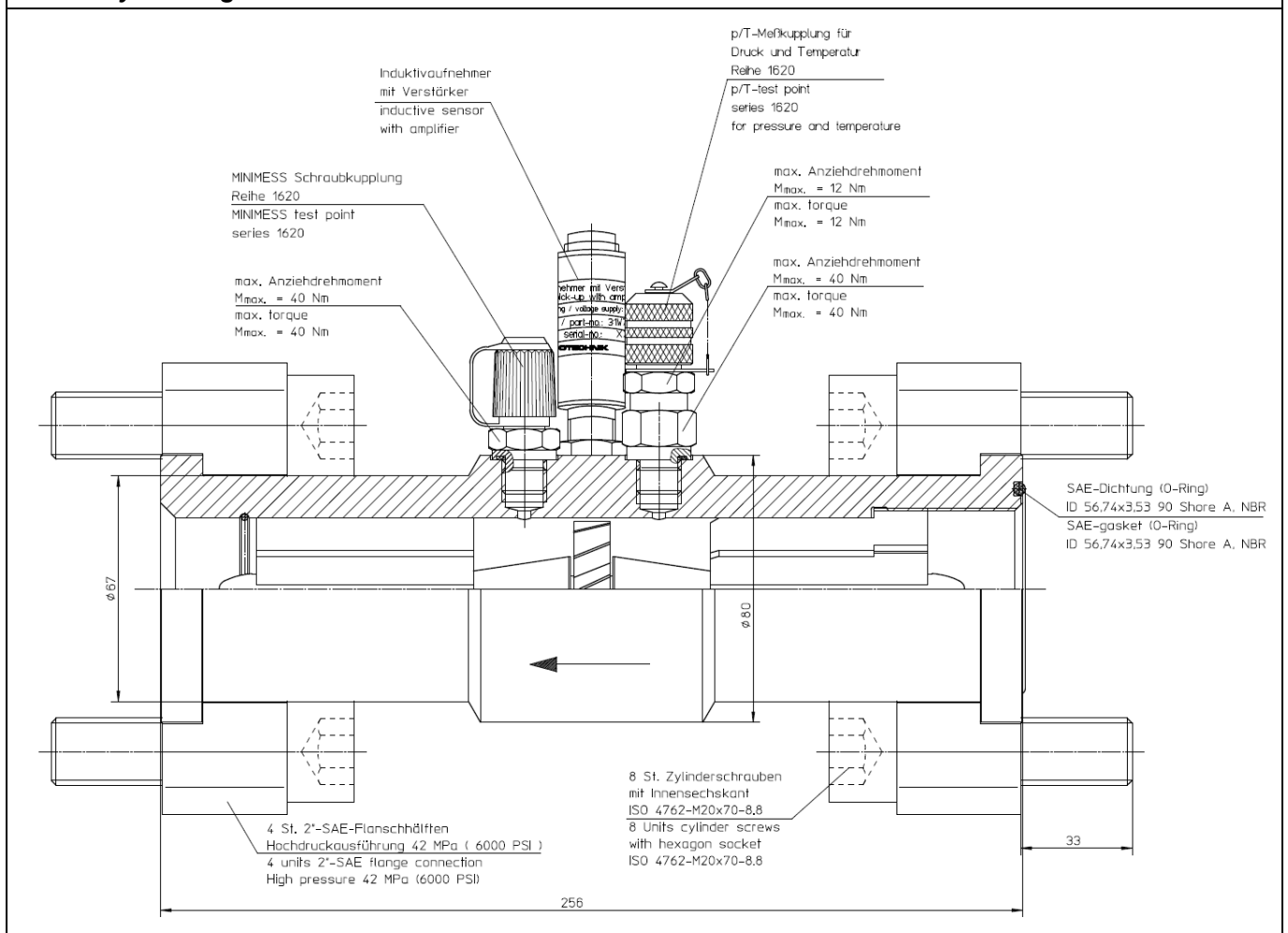

**Baugruppen-Zeichnung**  
**Assembly drawing**

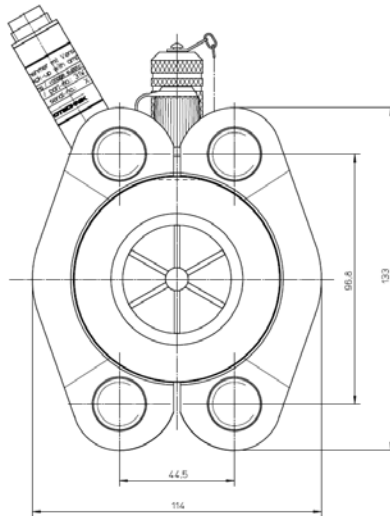

**Baugröße und Eigenschaften**  
**Design size and specifications**

SAE 2" [L/min]

Baugröße Size	Anschlussgewinde Connection size	Max. Druck Max. pressure		Gewicht Weight	Rohr Ø Pipe Ø	Länge Lenght
		[bar]	[psi]			
QT 3xx 1000L/min	2"-SAE-Flansch"	420	6000	ca. 795	67	256

SAE 2" [GPM]

Baugröße Size	Anschlussgewinde Connection size	Max. Druck Max. pressure		Gewicht Weight	Rohr Ø Pipe Ø	Länge Lenght
		[bar]	[psi]			
QT 3xx 270GPM	2"-SAE-Flansch	420	6000	ca. 795	67	256

**Differenzdruck**  
**Pressure difference**

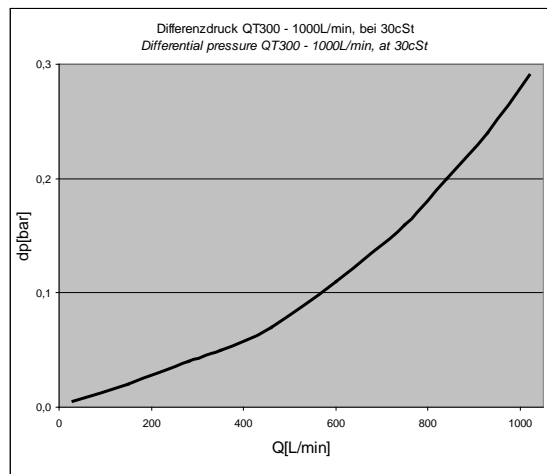

<b>Sensorhöhe</b> <i>sensor height</i>				
Baugröße <i>Design siz</i>	QT 300	QT 306	QT 310	QT 318
	[mm]	[mm]	[mm]	[mm]
QT 3xx 1000L/min	62	98		
QT 3xx 270GPM				

<b>Einbauhinweise</b> <i>Installation instructions</i>	<ul style="list-style-type: none"> <li>• Einbaulage beliebig, standardmäßige Strömung in Pfeilrichtung</li> <li>• Vor dem Einbau Anlage von Verunreinigungen befreien</li> <li>• Keine Schmutzpartikel &gt;25µm im Messfluid</li> <li>• Nach dem Einbau langsam mit Betriebsmittel füllen und Leitungen entlüften</li> <li>• Starke Querschnittsänderungen in der Einlaufstrecke vermeiden</li> <li>• Empfohlene gerade Einlaufstrecke vor der Messturbine ist 30 x Nenndurchmesser</li> <li>• Empfohlene Auslaufstrecke nach der Turbine 10 x Nenndurchmesser</li> <li>• Keine Faserdichtungen verwenden, Gewindedichtmittel für Anschlussstücke verwenden (z.B. Loctite 577)</li> <li>• Zum Lieferumfang gehören:               <ul style="list-style-type: none"> <li>○ 4 St. SAE-Flanschhälften 2",gerade Ausführung</li> <li>○ 1 St. SAE-Dichtung</li> <li>○ 8 St. Zylinderschrauben DIN 912</li> </ul> </li> </ul>	<ul style="list-style-type: none"> <li>• <i>Any mounting position possible, standard flow in direction of arrow</i></li> <li>• <i>Before mounting, clean the system by thoroughly rinsing of contaminants</i></li> <li>• <i>No particles &gt; 25µm in the fluid</i></li> <li>• <i>After mounting, please fill slowly with the operating medium and vent the pipes</i></li> <li>• <i>Avoid strong cross-sectional changes in the inlet zone</i></li> <li>• <i>Recommended straight inlet zone of the turbine is 30 x nominal diameter</i></li> <li>• <i>Recommended outlet zone of the turbine is 10 x nominal diameter</i></li> <li>• <i>Don't use fiber gasket, use thread gasket for fittings (for example Loctite 577)</i></li> <li>• <i>The package includes:</i> <ul style="list-style-type: none"> <li>○ <i>4 Units SAE flange connection 2", straight</i></li> <li>○ <i>1 Unit SAE seal</i></li> <li>○ <i>8 Units cylinder screws DIN 912</i></li> </ul> </li> </ul>
	Anzugsmomente (Toleranz +10%, Edeltstahlgewinde schmieren) <i>Recommended tightening torque (tolerance +10%, thread lubricated)</i>	
	MINIMESS® ISO228-G 1/4 <i>Torque MINIMESS® ISO228-G 1/4</i>	40 Nm
	MINIMESS® 7/16-20 UNF (ANSI B1.1) <i>Torque MINIMESS® 7/16-20 UNF (ANSI B1.1)</i>	30 Nm
	Signalaufnehmer <i>Torque sensor nut</i>	10 Nm

Typenschlüssel für Turbinen Volumendurchflusssensoren QT 3xx  
Type code for turbine flow meter QT 3xx

Bestellbeispiel:

How to order:

3	1	V	F	-	88	-	3	5	.	030
Messgeräte / Sensorik allgemein / Instruments / Sensors general Medienverträglichkeit / Medium compatibility	Aufnehmer / sensor	Serie / series	Anschlussgewinde / Durchflussbereich connecting thread / flow range	Bestückung Pos.1 mounting Pos.1	Bestückung Pos.2 mounting Pos.2	Kalibrierviskosität calibration viscosity				
							010	10cSt		
							030	30cSt* (Standardkalibrierung)		
							046	46cSt		
							xxx	xxxcSt (auf Anfrage)		
							5	p/T-Messkupplung Reihe 1620 (Kennzahl 04)*		
							6	p/T-Messkupplung Reihe 1615 (Kennzahl 04)		
							2	Schraubkupplung Reihe 1615, Kunststoffkappe		
							3	Schraubkupplung Reihe 1620, Kunststoffkappe*		
							88	SAE 2" Code 62	45...1000 L/min	
	F	QT 3xx								
	C	QT 206 CAN, elektr. Anschluss M12, 5-pol.*								
	J	QT 310 Analog 4...20mA, elektr. Anschluss M16, 6-pol., ISDS*								
	V	QT 300 Frequenz, elektr. Anschluss M16, 6-pol., ISDS *								
1	Hydrauliköle und Öle auf Mineralölbasis *									
3										

Typenschild (exemplarisch)  
Type plate (example)

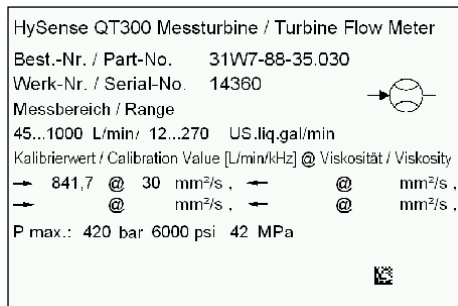

\*Standard



TKZ Order number	Zubehör und Ersatzteile Accessories and spare parts
8824-S1-xx.xxS <sup>1</sup>	Messkabel, Frequenz, 4...20mA, M16 6-pol. Stecker – M16 6-pol. Buchse <i>measuring cable frequency, 4...20mA, M16 6-pole connector – 6-pole M16 socket</i>
8824-S1-xx.xxH <sup>1</sup>	Messkabel, Frequenz, 4...20mA, ISDS, M16 6-pol. Stecker – M16 6-pol. Buchse (High End) <i>measuring cable frequency, 4...20mA, M16 6-pole connector – 6-pole M16 socket (High End)</i>
8824-S6-xx.xxS <sup>1</sup>	Messkabel, Frequenz, 4...20mA, M16 6-pol. Stecker – offenes Kabelende <i>measuring cable frequency, 4...20mA, M16 6-pole connector – open cable end</i>
8824-S6-xx.xxH <sup>1</sup>	Messkabel, Frequenz, 4...20mA, ISDS, M16 6-pol. Stecker – offenes Kabelende (High End) <i>measuring cable frequency, 4...20mA, M16 6-pole connector – open cable end (High End)</i>
8824-S2-xx.xxS <sup>2</sup>	Adapterkabel, Frequenz, 4...20mA, M16 5-pol. Stecker – M16 6-pol. Buchse <i>adapter cable frequency, 4...20mA, M16 5-pole connector – 6-pole M16 socket</i>
8824-S2-xx.xxH <sup>2</sup>	Adapterkabel, Frequenz, 4...20mA, ISDS, M16 5-pol. Stecker – M16 6-pol. Buchse (High End) <i>adapter cable frequency, 4...20mA, M16 5-pole connector – 6-pole M16 socket (High End)</i>
8824-S3-xx.xxS <sup>3</sup>	Verlängerungskabel, Frequenz, 4...20mA, M16 6-pol. Stecker – M16 6-pol. Buchse <i>extension cable frequency, 4...20mA, M16 6-pole connector – 6-pole M16 socket</i>
8824-S3-xx.xxH <sup>3</sup>	Verlängerungskabel, Frequenz, 4...20mA, M16 6-pol. Stecker – M16 6-pol. Buchse (High End) <i>extension cable frequency, 4...20mA, M16 6-pole connector – 6-pole M16 socket (High End)</i>
8824-S4-xx.xxS <sup>4</sup>	Messkabel Doppelsignalabgriff bei Frequenzeingang <i>measuring cable double signal connection for frequency output</i>
8824-M8-xx.xx <sup>5</sup>	Messkabel CAN, M12 5-pol. Buchse – offenes Kabelende <i>measuring cable CAN for MS 5060, M12 5-pole socket – open cable end</i>
8824-R7-02.50	Messkabel CAN für MS 4010 und MS 5060plus / M12 5-pol. Buchse – M12 8-pol. Stecker <i>measuring cable CAN for MS 4010 and 5060plus / M12 5-pole socket – M12 8-pole connector</i>
8824-M5-02.50	Messkabel CAN für MS 5060, M12 5-pol. Buchse – M12 8-pol. Stecker <i>measuring cable CAN for MS 5060, M12 5-pole socket – M12 8-pole connector</i>
8824-V1-02.50	Messkabel, Frequenz, 4...20mA, M12 4-pol. Stecker – offenes Kabelende <i>measuring cable frequency, 4...20mA, M12 4-pole connector – open cable end</i>
8824-V3-02.50H	Messkabel, Frequenz, 4...20mA, M12 4-pol. Stecker – offenes Kabelende (High End) <i>measuring cable frequency, 4...20mA, M12 4-pole connector – open cable end (High End)</i>
2149-04-15.50N	p/T MINIMESS®-Testpunkt (FKM), ISO 228 G1/4" <i>p/T MINIMESS®-test point (FKM), ISO 228 G1/4"</i>
2103-30-18.10N	p MINIMESS®-Testpunkt (FKM), ISO 228 G1/4" <i>p MINIMESS®-Testpunkt (FKM), ISO 228 G1/4"</i>
34P3-15-S-01.37A2	HySense PR 400, 4...20mA, IP67, 0...40 MPa / Drucksensor <i>HySense PR 400, 4...20mA, IP67, 0...40 MPa / pressure sensor</i>

<sup>1</sup> Verfügbare Standardlängen: 02.50 = 2,5m; 05.00 = 5,0m; 10.00 = 10,0m. *Available standard lengths: 02.50 = 2,5m; 05.00 = 5,0m; 10.00 = 10,0m.*

<sup>2</sup> Verfügbare Standardlängen: 00.30 = 0,3m; 02.50 = 2,5m; 05.00 = 5,0m; 10.00 = 10,0m. *Available standard lengths: 00.30 = 0,3m; 02.50 = 2,5m; 05.00 = 5,0m; 10.00 = 10,0m.*

<sup>3</sup> Verfügbare Standardlängen: 10.00 = 10,0m; 20.00 = 20,0m. *Available standard lengths: 10.00 = 10,0m; 20.00 = 20,0m.*

<sup>4</sup> Verfügbare Standardlängen: 00.20 = 0,2m; 00.50 = 0,5m. *Available standard lengths: 00.20 = 0,2m; 00.50 = 0,5m.*

<sup>5</sup> Verfügbare Standardlängen: 05.00 = 5,0m; 10.00 = 10,0m. *Available standard lengths: 05.00 = 5,0m; 10.00 = 10,0m.*

TKZ Order number	Zubehör und Ersatzteile Accessories and spare parts
3969-04-S-01.00S	HySense TE 110, 4...20mA, IP64, -50...200 °C / Temperatursensor <i>HySense TE 110, 4...20mA, IP64, -50...200 °C / temperature sensor</i>
3763-03-34.00	HySense TP 180, 4...20mA, IP40, 0...60 MPa / Druck- / Temperatursensor <i>HySense TP 180, 4...20mA, IP40, 0...60 MPa / pressure / temperature sensor</i>
3410-1600-A233F03	HySense RS 500, Frequenz, M16 6-pol. Stecker <i>HySense RS 500, frequency, M16 6-pol. connector</i>
3410-1600-A211F07	HySense RS 500, Frequenz, M12 4-pol. Stecker <i>HySense RS 500, frequency, M12 4-pol. connector</i>
3410-1400-A133Z1S	HySense RS 510, analog 4...20mA, M16 6-pol. Stecker <i>HySense RS 510, analog 4...20mA, M16 6-pol. connector</i>
3410-1400-A233Z1S	HySense RS 510, analog 4...20mA, M12 4-pol. Stecker <i>HySense RS 510, analog 4...20mA, M12 4-pol. connector</i>
3410-1400-A213C11	HySense RS 506, CAN, M12 5-pol. Stecker <i>HySense RS 506, CAN, M12 5-pol. connector</i>

**Rekalibrierung von Volumendurchflusssensoren**  
**Recalibration from flow sensors**

Jeder Turbinen Durchflusssensor besitzt seine individuelle Messcharakteristik, welche selbst bei gleichen Sensortypen sowie -größen variiert. Grund hierfür sind die mechanischen Fertigungstoleranzen, welche bei dynamischen Präzisionssensoren massiven Einfluss auf die Messcharakteristik haben. Resultierend daraus muss jeder neue Sensor kalibriert und justiert werden, um eine spezifizierte Messperformance sicherzustellen. Wird ein Sensor im Feld betrieben, erfolgt in Abhängigkeit der Betriebsart und der Betriebsbedingungen eine zeitliche Änderung der Messcharakteristik. Diese Veränderung resultiert aus Überlastbetrieb, Ablagerungen, Kontaminierung, Alterung sowie Änderung der Medieneigenschaften. Die Veränderung der Messcharakteristik kann sich negativ auf die Messperformance auswirken. Dies kann nicht im Vorfeld prognostiziert werden und ist vom Einsatz abhängig. Infolgedessen sollte jeder Sensor in bestimmten Intervallen recalibriert werden, um diese Veränderung festzustellen und ggf. zu kompensieren. Wir empfehlen die folgenden Intervalle. Liegen jedoch empirische Daten vor, sollte die Definition auf dieser Basis getroffen werden.

*Each turbine flow sensor has an own measuring characteristic, which varies even with the same sensor type and sizes. The reason for this difference is the mechanical manufacturing tolerances, which have a major influence on the measurement characteristic. Each new sensor must be calibrated and adjusted to ensure the specified measurement performance. If a sensor is operated in the field, a temporal change in the measurement characteristics occurs depending on the operating mode and the operating conditions. This change results from overload operation, deposits, contamination, aging and changes in media properties. The change in the measurement characteristics can have a negative effect on the measurement performance. This can't be predicted in advance and depends on the deployment. As a result, each sensor should be recalibrated at certain intervals in order to detect and, if necessary, compensate for this change. We recommend the following intervals. If empirical data are available, the definition should be made on this basis.*



<b>Rekalibrierung von Volumendurchflusssensoren</b> <i>Recalibration from flow sensors</i>	
<ul style="list-style-type: none"> <li>• Laboreinsatz (temp. Einsatz als Mastergeber mit geringer Einsatzdauer) → 36 Monate</li> <li>• Standardgebrauch (temp. Einsatz bei Teillast) → 24 Monate</li> <li>• Erhöhte Belastung (station. Einsatz bei Teillast) → 12 Monate</li> <li>• Extreme Belastung (station. Einsatz bei Vollast) → 6 Monate</li> </ul>	<ul style="list-style-type: none"> <li>• <i>Laboratory application (temporary use as a master encoder with a short operating time)</i> → 36 months</li> <li>• <i>Standard use (temporary use with partial load)</i> → 24 months</li> <li>• <i>Increased load (stationary use with partial load)</i> → 12 months</li> <li>• <i>Extreme load (steady load at full load)</i> → 6 months</li> </ul>

<b>Umrechnung, Durchfluss ↔ Strom</b> <i>Conversion, flow rate ↔ current</i>	
Durchfluss → Strom <i>flow rate → current</i>	Strom → Durchfluss <i>current → flow rate</i>
$I(Q_{\text{read}}) = \frac{16 \text{ mA} \cdot Q_{\text{read}}}{Q_{\text{max}}} + 4 \text{ mA}$	$Q(I_{\text{read}}) = \frac{Q_{\text{max}} \cdot (I_{\text{read}} - 4 \text{ mA})}{16 \text{ mA}}$

<b>Europäische Konformität</b> <i>European Conformity</i>		
Elektromagnetische Verträglichkeit / <i>electromagnetic compatibility</i>	Richtlinie 2004/108/EG	Directive 2004/108/EG
Druckgeräte / <i>pressure equipment</i>	Richtlinie 2014/68/EU	Directive 2014/68/EU

<b>REACH-Regulation (EU)</b> <b>No.1907/2006, Art. 33</b>	Die HYDROTECHNIK GmbH ist als Hersteller von Erzeugnissen, im Sinne der REACH-Verordnung, nachgeschalteter Anwender geringer Mengen und somit nicht registrierungspflichtig. Wir liefern ausschließlich nicht chemische Produkte (Erzeugnisse). Diese beinhalten keine Stoffe, die nach REACH Artikel 7 unter normalen oder vernünftigerweise vorhersehbaren Verwendungsbedingungen zur Freisetzung beabsichtigt sind.	<i>HYDROTECHNIK GmbH as a manufacturer of products is, with regard to the REACH regulation, a downstream-user of small quantities. As such it is not obliged to register. We exclusively supply non-chemical products. These do not contain substances which, according to REACH Article 7, are intended for release under normal or reasonably foreseeable conditions of use.</i>
--	--	--

<b>Haftungsausschuss</b> <b>Limitation of Liability</b>	Hydrotechnik behält sich Änderungen an diesem Dokument vor, ohne vorherige Information. Im Zweifelsfall gilt die deutsche Sprachversion. Angaben in Klammern dienen nur zur Information.	<i>Hydrotechnik reserves the right to modify this document without prior notice. The German language version is valid in any case of doubt. Data in brackets only given for information.</i>
--	--	--

**Teil 2** **Eigenschaften nach Ausgangssignal**  
**Part 2** **Parameters for output signal**

**Frequenz**

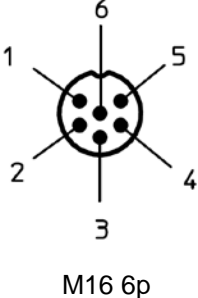
Pinbelegungen <i>Pin assignments</i>	Bezeichnung <i>Labeling</i>	Nr. <i>No</i>	Funktion	<i>Function</i>
Rundsteckverbinder M16 x 0.75 mit Schraubverriegelung, Ausführung 06-a, 6-polig, Stecker <i>Circular connectors M16 x 0.75 with screw-locking Layout 06-a, 6 poles, male IEC / DIN EN 61076-2-106</i>				
	<b>QT 300 Frequenz / Frequency</b>			
	f-Signal	1	Frequenzsignal	<i>Frequency signal</i>
	GND	2	Masse	<i>Ground</i>
	+Ub	3	Versorgungsspannung	<i>Supply voltage</i>
	NC	4	nicht verbunden	<i>not connected</i>
	NC	5	nicht verbunden	<i>not connected</i>
	ISDS	6	Sensorerkennung	<i>Sensor detection</i>

Messgenauigkeit <i>Accuracy</i>				
Kalibrierter Bereich <i>Calibrated range</i>				Messgenauigkeit <i>Accuracy</i>
L/min		GPM		%
45	1000	12	270	± 3.0 vom Messwert / <i>of reading</i>

**CAN**

Pinbelegungen <i>Pin assignments</i>	Bezeichnung <i>Labeling</i>	Nr. <i>No</i>	Funktion	Function
Rundsteckverbinder M12 x 1 mit Schraubverriegelung A-Kodierung, 5-polig, Stecker IEC / DIN EN 61076-2-101 <i>Circular connectors M12 x 1 with screw-locking A-coding, 5 poles, male IEC / DIN EN 61076-2-101</i>				
	<b>QT 306 CAN</b>			
	CAN SHLD	1	CAN Schirm	<i>CAN Shield</i>
	CAN V+	2	CAN Versorgung	<i>CAN Supply</i>
	CAN GND	3	CAN Masse	<i>CAN Ground</i>
	CAN H	4	CAN High	<i>CAN High</i>
	CAN L	5	CAN Low	<i>CAN Low</i>

Messgenauigkeit <i>Accuracy</i>				
Kalibrierter Bereich <i>Calibrated range</i>				Messgenauigkeit <i>Accuracy</i>
L/min		GPM		%
45	1000	12	270	± 0.5 vom Messwert / <i>of reading</i>

CANopen Parameter					
Übertragungsrate / <i>transfer rate</i>	20		1000	kBit/s	
PDO / <i>process data object</i>		1			
Knoten Nr. / <i>Node Id.</i>		10			(hex = 0x0A)
COB ID PDO1		394			(hex = 0x18A)
Senderate / <i>sending rate</i>	10		1000	ms	
Geräte Status / <i>node state</i>		pre-operational			
Prozessdaten: <i>process data</i>					
Frequenz / <i>frequency</i>		fx1000		Hz	
Signaltyp / <i>value type</i>		ulong		Bytes	Byte [0...3]
Beispiel / <i>example</i>					1kHz => 0x000F4240
Volumenstrom / <i>flow rate</i>		Qx1000		l/min	alternativ gal / min
Signaltyp / <i>value type</i>		ulong		Bytes	Byte [4...7]
Beispiel / <i>example</i>					200l/min => 0x00030D40

Analog 4...20mA

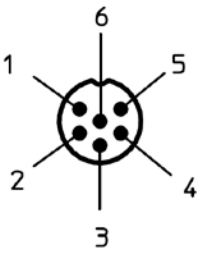
Pinbelegungen <i>Pin assignments</i>	Bezeichnung <i>Labeling</i>	Nr. <i>No</i>	Funktion	<i>Function</i>
Rundsteckverbinder M16 x 0.75 mit Schraubverriegelung, Ausführung 06-a, 6-polig, Stecker <i>Circular connectors M16 x 0.75 with screw-locking Layout 06-a, 6 poles, male IEC / DIN EN 61076-2-106</i>				
 <p>M16 6p</p>	<b>QT 310 4...20 mA 2-Draht / 2-wire</b>			
	Signal	1	Signal	<i>Signal</i>
	ISDS GND <sup>6</sup>	2	Masse	<i>Ground</i>
	+Ub	3	Versorgungsspannung	<i>Supply voltage</i>
	NC	4	nicht verbunden	<i>not connected</i>
	NC	5	nicht verbunden	<i>not connected</i>
	ISDS	6	Sensorerkennung	<i>Sensor detection</i>

Messgenauigkeit <i>Accuracy</i>				
Kalibrierter Bereich <i>Calibrated range</i>			Messgenauigkeit <i>Accuracy</i>	
L/min		GPM		%
45	1000	12	270	± 3.2 vom Messwert / <i>of reading</i>

Revision	Rev 00	Rev 01	Rev 02	Rev 03	Rev 04	Rev 05	Rev 06	Rev 07
	2018-04-05							
	MH							

<sup>6</sup> Der Masse-Anschluss bei QT310 bezieht sich ausschließlich auf die ISDS-Kommunikation.  
*Ground pin of QT310 referring to ISDS communication exclusively.*