

MINIMESS®



HYDROTECHNIK
TEST WITH CONFIDENCE

Preface

Pioneering technology and innovative solutions

The company philosophy “Test with confidence” has a long tradition at Hydrotechnik. In 1964, the MINIMESS® - ball sealing threaded test point and plug-in coupling was invented and proved to be a major advance for pressure measurement on hydraulic systems.

The benefits of this innovative development were vast because up till then, pressure measurements had been mainly carried out with help of fixed mounted pressure gauges and with enormous expenditure. Now, with Hydrotechnik, the use of pressure sensors and pressure gauges could now be carried out quickly, safely and **without any interruptions** to plant. This is why we say “**Test with confidence**”.

The next step: New sealing technique

As a consequent development of the MINIMESS® - plug-in and threaded test point with ball sealing from the 60's, the patented leakage-free coupling with soft-sealing was introduced.

The added benefits to our customers were at the forefront of our mind, meaning cleaner handling and new applications in problematic areas like water protection zones and for the first time also in gas application, which established HYDROTECHNIK even further in the market.

p/T coupling - for requirements in the present and the future

Handling, operating characteristics and quality of the MINI-MESS® - test points have been proved a million times, however “Test with confidence” stands also for research and development. In order to offer more innovative products to our customers, new demands in the automation and robotics sector caused the next development. Our aim was to avoid measuring pressure and temperature with separate sensors. Instead, we wanted to use one common Test Point.

Hydrotechnik developed the p/T - coupling, which was lengthened and designed to accept a temperature probe which actually gets in contact with the medium. Perfect heat transmission between the medium and the temperature sensor is guaranteed.

Reliability and quality

The high quality standard, connected with large process-security and non-leakage are reached by a modern automatic assembling with integrated leak testing.

Due to this fact, ultra-modern test- and measurement couplings from Hydrotechnik are available to everyone.

Today, MINIMESS® - couplings are the basic requirement for measuring and testing in industry worldwide, due to its enormous environmental security and economy.



Convince yourself and “Test with confidence”.

MINIMESS® –
One product for many applications

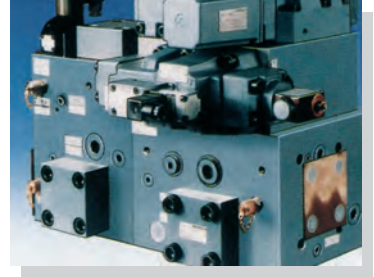
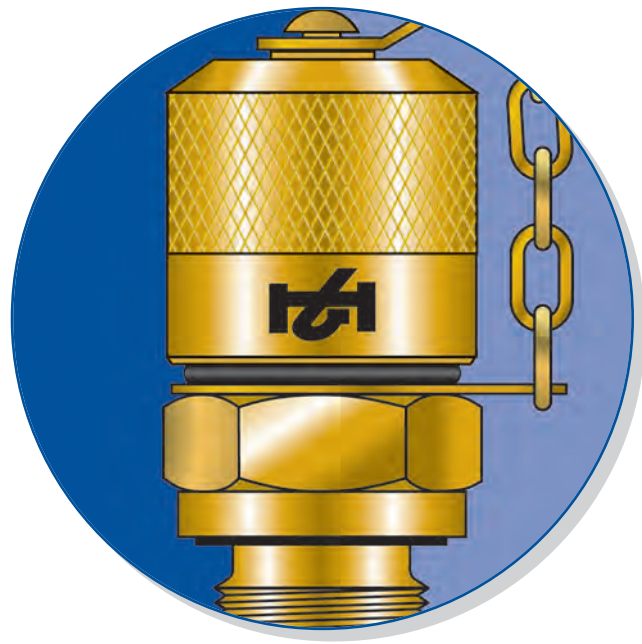

Hydraulic control blocks

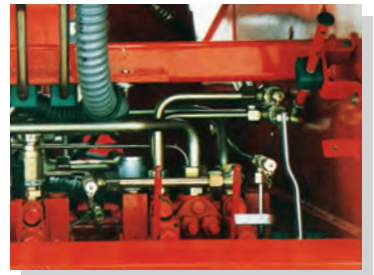

Mobile load sensing systems



Pump drives

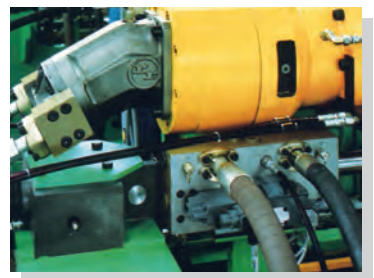

Cylinder controls



Servo valves

Contents

MINIMESS®-Index

- 6 **MINIMESS® – an overview**
- 7 **MINIMESS®-Technical data**
- 8 **MINIMESS®-1620 Test Points**
 - Metric DKO, Tee Adaptors - 1620
 - Metric DKO 1620 Male/Female Tee Adaptors
 - 1620 Bulkhead Adaptors
 - 1620 Standpipe adaptor 37°-edged screwing SAE J514
 - MINIMESS®-1620 pressure gauge connection for bulkhead fitting
 - MINIMESS®-1620 pressure gauge - direct connection
 - 1620 90° Swivel screw connection
 - MINIMESS®-1620 Hose adaptors
- 12 **MINIMESS® - 1620 p/T Test Points**
- 13 **MINIMESS®- 1215 Test Points**
 - Metric DKO, Tee Adaptors - 1215
 - 1215 Bulkhead Adaptors
 - MINIMESS®-1215 pressure gauge connection for bulkhead fitting
 - MINIMESS®-1215 pressure gauge - direct connection
 - 1215 90° Swivel screw connection
 - MINIMESS®-1215 hose adaptors
- 16 **MINIMESS®-1615 Test Points**
 - MINIMESS®-1615 specialised options
 - Metric DKO, Tee Adaptors - 1615
 - 1615 Bulkhead adaptors
 - MINIMESS®-1615 pressure gauge connection for bulkhead fitting
 - MINIMESS®-1615 pressure gauge - direct connection
 - 1615 90° Swivel screw connection
 - MINIMESS®-1615 Hose Adaptors
- 19 **MINIMESS®-1604 Test Points**
- 19 **MINIMESS®-Plug-in Test Points**
- 20 **MINIMESS®-Pressure inhibitors and accessories**
- 21 **MINIMESS®-Technical data on DN2 and DN4 microbore hose**
- 23 **Mounting suggestions of MINIMESS® microbore hose assemblies**
- 24 **MINIMESS®-DN2 microbore hose assemblies 1620,1615, 1215 and plug-in series**
 - Measuring hoses DN2 with protection against leakage
- 25 **MINIMESS®-DN4 microbore hose assemblies 1604**
 - Measuring hoses DN4 with protection against leakage
- 26 **Order chart for hose material and accesories DN2 and DN4**
- 27 **Selectable hose ends for DN2 and DN4 hose**
- 31 **Accessories for MINIMESS®-hoses**
- 32 **Digital pressure gauges**
 - MINIMESS®-1620 Test kit with two digital pressure gauges
- 33 **Analogue pressure gauges**
 - MINIMESS®-1620 Test kit with two analogue gauges
- 35 **Accumulator charging and testing devices**
- 36 **MINIMESS®-gas charging valve 1615**
- 37 **Accumulator charging and testing devices**
- 37 **Gas charging and testing devices with pressure reducer valve**
- 37 **Gas charging and flushing devices with pressure reducer valve**
- 38 **Compatibility table**
- 39 **Conversion table of pressure measuring units**

MINIMESS® – an overview

MINIMESS®-1620



Thread of screw-cap	Nominal Bore	Max Pressure	Material	Sealing material	Page
M 16 x 2	DN 2	63,0 MPa	Free-cutting steel 1.0718 Stainless steel 1.4571	NBR (Perbunan) FKM (Viton)	8

MINIMESS®-p/T 1620



Thread of screw-cap	Nominal Bore	Max Pressure	Material	Sealing material	Page
M 16 x 2	DN 2	63,0 MPa	Free-cutting steel 1.0718	NBR (Perbunan) FKM (Viton)	12

MINIMESS®-1215



Thread of screw-cap	Nominal Bore	Max Pressure	Material	Sealing material	Page
Fixing thread 12	DN 2	63,0 MPa	Free-cutting steel 1.0718 Stainless steel 1.4571	NBR (Perbunan) FKM (Viton)	13

MINIMESS®-1615



Thread of screw-cap	Nominal Bore	Max Pressure	Material	Sealing material	Page
M 16 x 1,5	DN 2	63,0 MPa	Free-cutting steel 1.0718 Stainless steel 1.4571	NBR (Perbunan) FKM (Viton)	16

MINIMESS®-1604



Thread of screw-cap	Nominal Bore	Max Pressure	Material	Sealing material	Page
Fixing thread 16	DN 4	40,0 MPa	Free-cutting steel 1.0718	NBR (Perbunan) FKM (Viton)	19

MINIMESS®-Technical data

Max. working pressure 63 MPa (630 bar) according to ISO 15171-2

Material

Coupling body and metal cap made of steel 1.0718
 Note: Unless stated otherwise, all products shown in this catalogue are made of free-cutting steel 1.0718

Sealing

Internal primary- and secondary sealing as well as sealing for screw-in threads are made of NBR (Perbunan). Option in FKM (Viton).

Vibration

NBR (Perbunan) and/or FKM (Viton) O-ring to prevent cap loosening due to vibration.

Screw-in thread

Large range of threads are available.

Media application

Suitable for hydraulic- and other oils on mineral oil basis

Temperature ranges at applications with metal cap (standard)

Sealing made of NBR (Perbunan): -25 °C to +100 °C,
 for a short time, can be also used up to +120 °C

Sealing made of FKM (Viton) as option: -20 °C to +200 °C

Application with plastic cap (option)
 and for both sealing materials: -20 °C to +100 °C

Application for low temperature: -54 °C on request

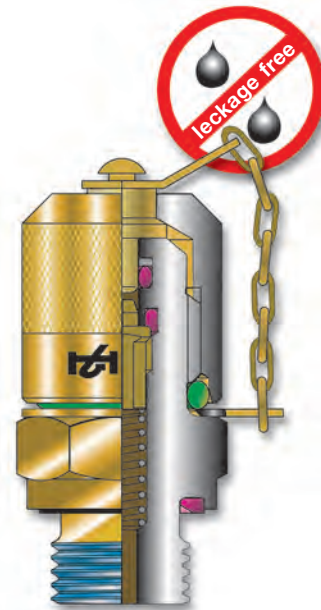

Gradually change over to chrome (VI)-free surface treatment

Thread form data

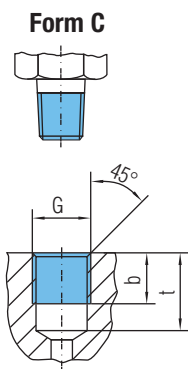

Thread port according to DIN 3852 part 1 and part 2, form Z (sealed with suitable sealant)

G	b	t
ISO 7/1 - R1/8	5,5	9,5
ISO 7/1 - R1/4	8,5	13,5

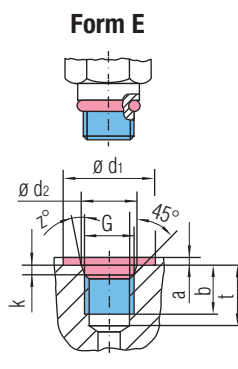

Thread port according to SAEJ 514 (UNF) or according to ISO 6149-1 (sealed with O-ring)

SAE J 514 (UNF)

G	d ₁	d ₂	b	k	t	a	z°
7/16-20 UNF	21,0	12,4	11,5	2,4	14,0	1,6	12,0
1/2-20 UNF	23,0	14,0	11,5	2,4	14,0	1,6	12,0
9/16-18 UNF	25,0	15,6	12,7	2,5	15,5	1,6	12,0
3/4-16 UNF	30,0	20,6	14,3	2,5	17,5	2,4	15,0

ISO 6149-1

M	d ₁	d ₂	b	k	t	a	z°
M 10 x 1	19,0	11,1	10,0	1,6	11,5	1,0	12,0
M 12 x 1,5	19,0	13,8	11,5	2,4	14,0	1,5	15,0
M 14 x 1,5	21,0	15,8	11,5	2,4	14,0	1,5	15,0
M 16 x 1,5	24,0	17,8	13,0	2,4	15,5	1,5	15,0

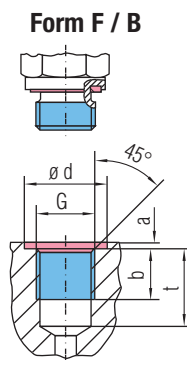

Thread Port up to Ø d according to DIN 3852 part 1 and part 2, form X (sealed with flat seal or sealing edge)

G	d	a	b	t
ISO 228-G 1/8	15,0	1,0	8,0	13,0
ISO 228-G 1/4	20,0	1,5	12,0	18,5
ISO 228-G 3/8	23,0	2,0	12,0	18,5
ISO 228-G 1/2	27,0	2,5	14,0	22,0
M 12 x 1,5	18,0	1,5	12,0	18,5
M 14 x 1,5	20,0	1,5	12,0	18,5
M 16 x 1,5	22,0	1,5	12,0	18,5

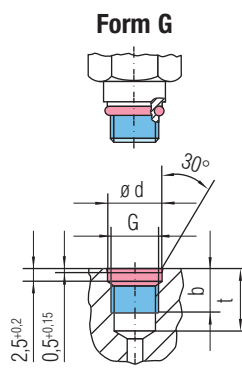

Thread Port according to HYDROTECHNIK standard N901-01-14 (sealed with O-ring)

G	d	b	t
M 8 x 1	9,5	9,0	13,0
M 10 x 1	11,5	9,0	13,0

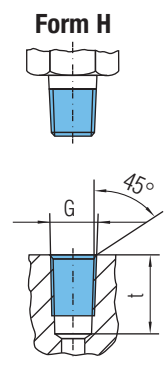



Thread Port according to ANSI/ASME B 1.20.1-1983 (self sealing thread)

G	t
1/8 NPTF	12,0
1/4 NPTF	17,5
1/2 NPTF	22,9

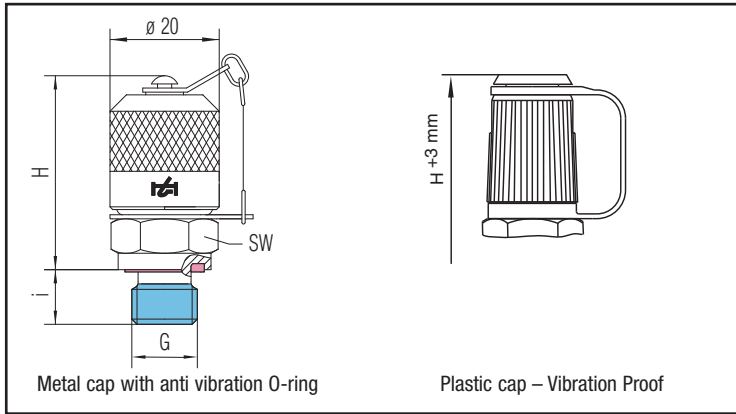
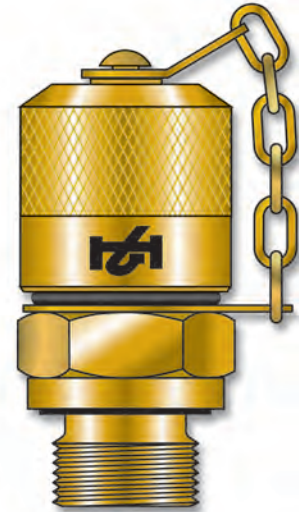
MINIMESS®-1620 Test Points

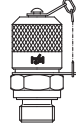

Thread G	Type of seal A	Torque in Nm	Technical data				Material: Free cutting steel 1.0718  Metal cap	Part-number with NBR - sealing	Material: Free cutting steel 1.0718  Plastic cap	Part-number with NBR - sealing	Material: Stainless steel 1.4571  Metal cap	Part-number with FKM - sealing
			p max	H in mm	i in mm	SW in mm						
M 8 x 1*	Form G	6	25 MPa	41	8,5	17	2103-01-32.00	2103-30-32.00	2103-01-32.00	on request		
M 10 x 1		12		37,5	8,5	17	2103-01-33.00				2703-01-33.10	
M 12 x 1,5	Form F	30	63 MPa	36	10	17	2103-01-13.00	2103-30-13.00	2103-01-13.00	on request		
M 14 x 1,5		40		36	10	19	2103-01-14.00				2703-01-14.10	
M 16 x 1,5		60		36	10	22	2103-01-15.00				on request	
M 14 x 1,5	Form E**	45	40 MPa	35,5	11	19	2103-01-96.00	2103-30-96.00	on request			
ISO 228-G 1/8	Form F	18		38	8	17	2103-01-17.00	2703-01-17.10				
ISO 228-G 1/4		40		36	10	19	2103-01-18.00	2703-01-18.10				
ISO 228-G 3/8		60	36	10	22	2103-01-16.00	on request					
1/8 NPTF	Form H	-	40 MPa	33	9,5	17	2103-01-46.00	2103-30-46.00	on request			
1/4 NPTF		-		33	16,5	17	2103-01-47.00	2703-01-47.10				
7/16-20 UNF	Form E	20	63 MPa	37	9	17	2103-01-21.00	2103-30-21.00	on request			
9/16-18 UNF		35		36	10	19	2103-01-53.00	on request				
ISO 7/I-R 1/8	Form C	-	40 MPa	33	13	17	2103-01-40.00	2103-30-40.00	on request			
ISO 7/I-R 1/4		-		33	13	17	2103-01-41.00	on request				

* M8x1 - Please do not use for new machinery design.
 ** Form E - ISO 6149-2.

Option

For sealing in FKM (Viton) Exchange end digits from 00 to 10	10
--	-----------

Other materials, designs, sealing and screw-in threads on request.
 We reserve the right to carry out technical modifications.

MINIMESS®-1620 Test Points

Metric DKO, Tee Adaptors - 1620

For solder free screw-in pipe connections according to DIN 2353; free-cutting steel 1.0718; sealing NBR

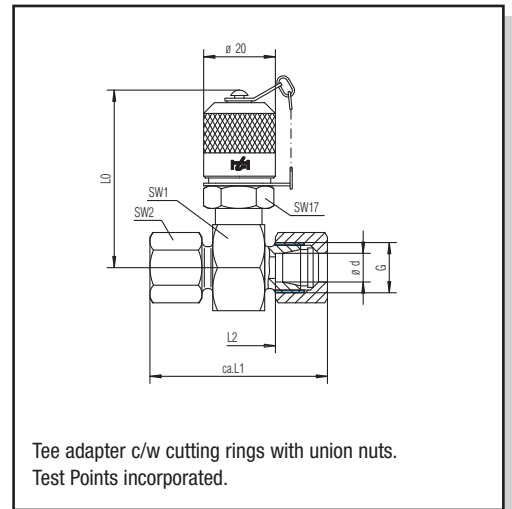
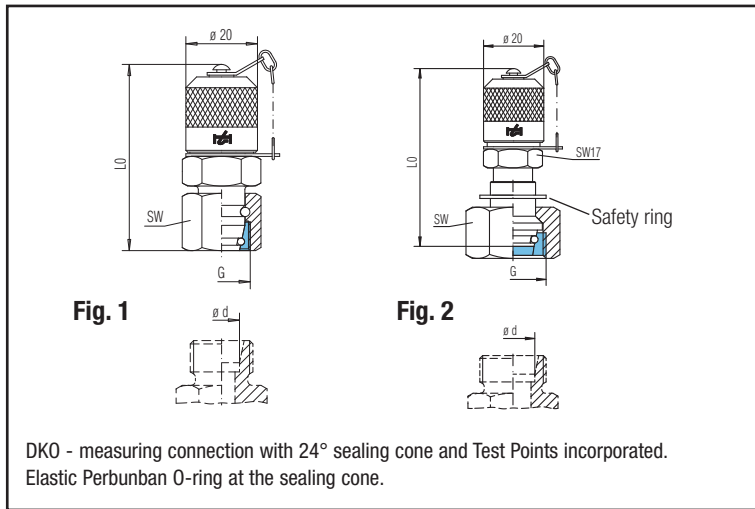

Series Ø d	p max	Thread G
L 6	31,5 MPa	M 12 x 1,5
L 8		M 14 x 1,5
L 10		M 16 x 1,5
L 12		M 18 x 1,5
L 15		M 22 x 1,5
L 18		M 26 x 1,5
L 22	16 MPa	M 30 x 2
L 28		M 36 x 2
L 35		M 45 x 2
L 42		M 52 x 2

Fig.	L ₀	SW	Part-number
1	52	14	2103-93-06.00
	52	17	2103-93-08.00
	52	19	2103-93-10.00
	52	22	2103-93-12.00
	52	27	2103-93-15.00
	52	32	2103-93-18.00
2	60	36	2103-40-22.00
	61	41	2103-40-28.00
	63	50	2103-40-35.00
	63	60	2103-40-42.00

L ₁	L ₂	L ₀	SW ₁	SW ₂	Part-number
50,5	20,5	49,5	24	14	2103-11-06.00
50,5	20,5	49,5	24	17	2103-11-08.00
52,5	22,5	49,5	24	19	2103-11-10.00
52,5	22,5	49,5	24	22	2103-11-12.00
54,5	24,5	52,5	30	27	2103-11-15.00
56,5	23,5	53,5	32	32	2103-11-18.00
60,5	27,5	55,5	36	36	2103-11-22.00
60,5	27,5	58	41	41	2103-11-28.00
68,5	25,5	60,5	46	50	2103-11-35.00
70,5	24,5	65	55	60	2103-11-42.00

Series Ø d	p max	Thread G
S 6	63 MPa	M 14 x 1,5
S 8		M 16 x 1,5
S 10		M 18 x 1,5
S 12		M 20 x 1,5
S 14	M 22 x 1,5	40 MPa
S 16	M 24 x 1,5	
S 20	M 30 x 2	
S 25	M 36 x 2	
S 30	M 42 x 2	
S 38	31,5 MPa	M 52 x 2

Fig.	L ₀	SW	Part-number	
1	52	17	2103-94-06.00	
	52	19	2103-94-08.00	
	52	22	2103-94-10.00	
	52	24	2103-94-12.00	
2	63	27	2103-41-14.00	
1	52	30	2103-94-16.00	
	63	36	2103-41-20.00	
	2	64,5	46	2103-41-25.00
		66	50	2103-41-30.00
		69	60	2103-41-38.00

L ₁	L ₂	L ₀	SW ₁	SW ₂	Part-number
54,5	24,5	49,5	24	17	2103-12-06.00
54,5	24,5	49,5	24	19	2103-12-08.00
56,5	23,5	49,5	24	22	2103-12-10.00
56,5	23,5	49,5	24	24	2103-12-12.00
62,5	26,5	51	27	27	2103-12-14.00
62,5	25,5	52,5	30	30	2103-12-16.00
68,5	25,5	55,5	36	36	2103-12-20.00
74,5	26,5	58	41	46	2103-12-25.00
80,5	27,5	60,5	46	50	2103-12-30.00
91	29	65	55	60	2103-12-38.00

Options

All sealing made of Viton with metal cap (when ordering, exchange end digits from 00 to 10)	10
With mounted plastic cap (when ordering, exchange end digits from 00 to 90)	90
All sealing made of Viton with plastic cap (when ordering, exchange end digits from 00 to 95)	95

MINIMESS®-1620 Test Points Metric DKO 1620 Male/Female Tee Adaptors

For solder free screw-in pipe connections according to DIN 2353

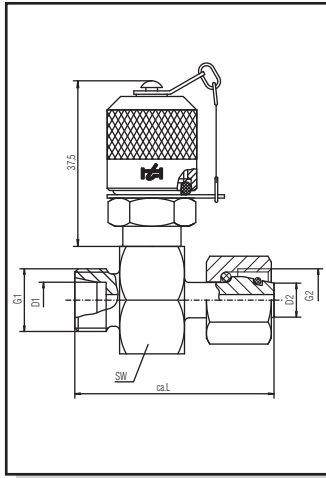

Series	p max	G1	D1	G2	D2	SW	L	Part-number
L 6	31,5 MPa	M 12 x 1,5	6	M 12 x 1,5	6	24	44,5	2103-KL-06.00
L 8		M 14 x 1,5	8	M 14 x 1,5	8	24	44,5	2103-KL-08.00
L 10		M 16 x 1,5	10	M 16 x 1,5	10	24	47,5	2103-KL-10.00
L 12		M 18 x 1,5	12	M 18 x 1,5	12	24	48,5	2103-KL-12.00
L 15		M 22 x 1,5	15	M 22 x 1,5	15	30	51,5	2103-KL-15.00
L 18	16 MPa	M 26 x 1,5	18	M 26 x 1,5	18	32	55,5	2103-KL-18.00
L 22		M 30 x 2	22	M 30 x 2	22	36	58,5	2103-KL-22.00
L 28		M 36 x 2	28	M 36 x 2	28	41	59	2103-KL-28.00
L 35		M 45 x 2	35	M 45 x 2	35	46	68	2103-KL-35.00
L 42		M 52 x 2	42	M 52 x 2	42	55	68	2103-KL-42.00

Series		G1	D1	G2	D2	SW	L	Part-number
S 6	63 MPa	M 14 x 1,5	6	M 14 x 1,5	6	24	46,5	2103-KS-06.00
S 8		M 16 x 1,5	8	M 16 x 1,5	8	24	48,5	2103-KS-08.00
S 10		M 18 x 1,5	10	M 18 x 1,5	10	24	49,5	2103-KS-10.00
S 12		M 20 x 1,5	12	M 20 x 1,5	12	24	50	2103-KS-12.00
S 14		M 22 x 1,5	14	M 22 x 1,5	14	27	53,5	2103-KS-14.00
S 16	40 MPa	M 24 x 1,5	16	M 24 x 1,5	16	30	56,5	2103-KS-16.00
S 20		M 30 x 2	20	M 30 x 2	20	36	64,5	2103-KS-20.00
S 25		M 36 x 2	25	M 36 x 2	25	41	66	2103-KS-25.00

MINIMESS®-1620 Test Points 1620 Bulkhead Adaptors

For solder free screw-in pipe connections according to DIN 2353, to MINIMESS® - 1620 Test Points, NBR sealing

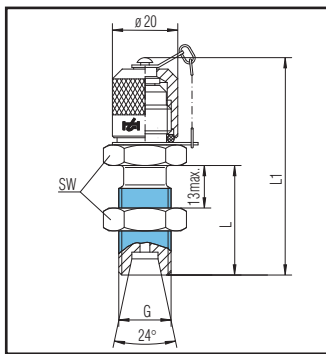

Thread G	p max	Connectoin	L in mm	L ₁ in mm	SW in mm	Part-number
M 12 x 1,5	31,5 MPa	L 6	34	67	17	2103-04-22.00
M 14 x 1,5		L 8	34	67	19	2103-04-23.00
M 16 x 1,5		L 10	33,5	66,5	22	2103-04-18.00
M 14 x 1,5	63 MPa	S 6	36	69	19	2103-04-24.00
M 16 x 1,5		S 8	33,5	66,5	22	2103-04-25.00
M 18 x 1,5		S 10	37	70	24	2103-04-26.00

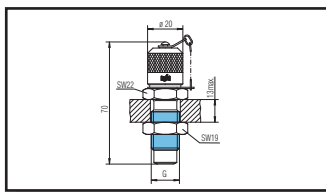

Thread G	p max	Connectoin	Part-number
M 16 x 2	63 MPa	Both sides for MINIMESS® 1620 (M 16 x 2)	2103-04-16.00

MINIMESS®-1620 Test Points 1620 Standpipe adaptor 37° - edged screwing SAE J514

NBR sealing

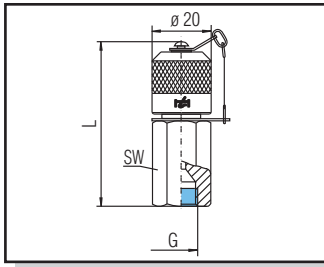

Thread G	p max	Pipe Ø in mm	Pipe Ø in inch	L in mm	SW in mm	Part-number
7/16-20 UNF	60 MPa	6	1/4"	55	17	2103-85-21.00
1/2 -20 UNF	42 MPa	8	5/16"	56,5	17	2103-85-22.00
9/16-18 UNF	31,5 MPa	10	3/8"	57,5	19	2103-85-23.00
3/4- 16 UNF		12	1/2"	60,5	22	2103-85-24.00

MINIMESS®- pressure gauge connection for bulkhead fitting

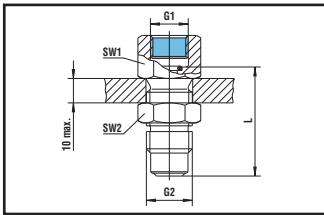

Internal thread G1	p max	Connection G2	L in mm	SW in mm	Note	Part-number
ISO 228-G 1/4	63 MPa	1620 / M 16 x 2	38	19	Without return valve	2103-05-11.00
ISO 228-G 1/2			42,5	27		2103-05-12.00
1/4 NPT			-	19		2103-05-23.00

MINIMESS®-1620 pressure gauge – direct connection

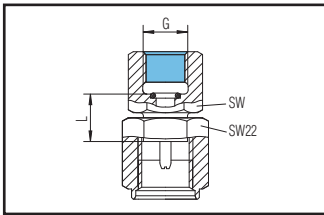

Internal thread G	p max	L in mm	SW in mm	Part-number
ISO 228-G 1/4	63 MPa	14,5	19	2103-07-11.62
ISO 228-G 1/2		17	27	2103-07-12.62
1/4 NPT		-	19	2103-07-23.62

MINIMESS®-1620 90° Swivel screw connection

NBR sealing

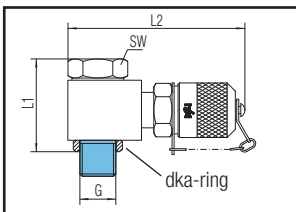

Thread G	p max	L ₁ in mm	L ₂ in mm	SW in mm	Part-number
ISO 228-G 1/4	63 MPa	34,5	64,5	19	2115-22-34.00

Sealing on screw-in thread (hollow screw) via dka-ring, on hexagon via Gi-ring (NBR). Other options on request.

MINIMESS®-1620 hose adaptor

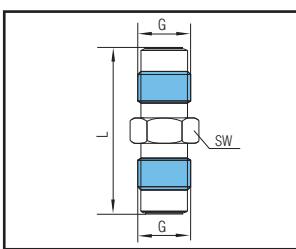

Thread G	p max	L in mm	SW in mm	Note	Part-number
M 16 x 2	63 MPa	42	17	Without return valve	2146-01-00.00

Other materials, further executions, sealing and screw-in threads on request.

MINIMESS®-1620 p/T Test Points

for pressure and temperature measurement

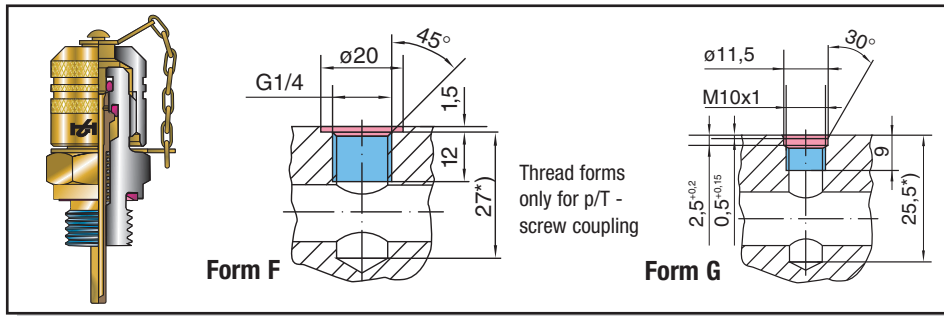
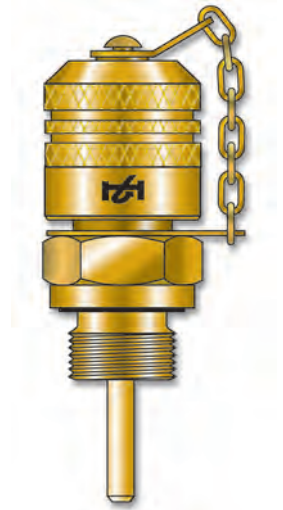

*) = recommended min. depth of drill

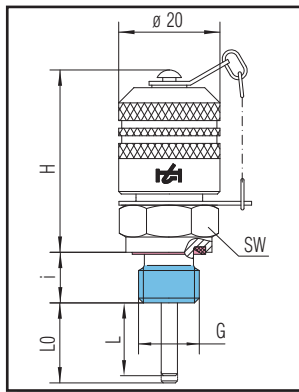

		Torque in Nm	Technical data						Material: Free cutting steel 1.0718  Metal cap
Thread G	Type of sealing A		p max	H in mm	i in mm	L ₀ in mm	L in mm	SW in mm	
ISO 228-G 1/4	Form F	40	63 MPa	36,5	10	16	14,5	19	Part-number with NBR - sealing 2149-04-15.13
M 10 x 1	Form G	12		38	8,5	16	14,5	17	2149-04-19.13

L₀ = max. immersion depth in coupled state, L = not coupled state

Option

For FKM (Viton) - exchange end digits from 13 to 53

53

Other materials, further options, sealing and screw-in threads on request.
We reserve the right to carry out technical modifications.

MINIMESS®-1215 Test Points

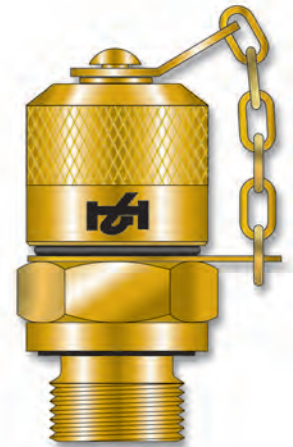
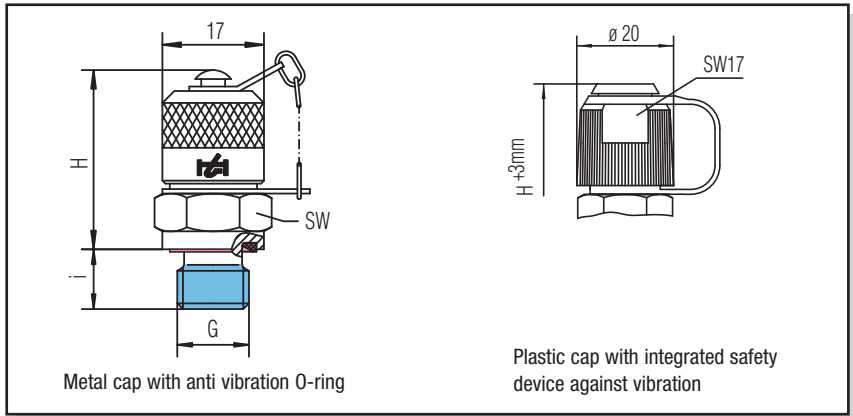

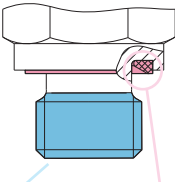
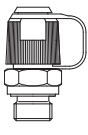
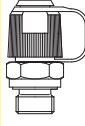
Thread G	Type of sealing A	Torque in Nm	Technical data				Material: Free cutting steel 1.0718  Metal cap	Part-number with NBR - sealing	Material: Free cutting steel 1.0718  Plastic cap	Part-number with NBR - sealing	Material: Stainless steel 1.4571  Metal cap	Part-number with FKM - sealing
			p max	H in mm	i in mm	SW in mm						
M 8 x 1*	Form G	6	25 MPa	30	8,5	14	2101-06-32.00	2101-01-32.00	on request			
M 10 x 1		12		30	8,5	14	2101-06-33.00	2101-01-33.00	2701-06-33.10			
M 12 x 1,5	Form F	30	63 MPa	29	10	17	2101-06-13.00	2101-01-13.00	on request			
M 14 x 1,5		40		29	10	19	2101-06-14.00	2101-01-14.00	on request			
ISO 228-G 1/8		18	40 MPa	30	8	14	2101-06-17.00	2101-01-17.00	on request			
ISO 228-G 1/4		40	63 MPa	29	10	19	2101-06-18.00	2101-01-18.00	2701-06-18.10			
1/8 NPTF	Form H	-	40 MPa	26	12	14	2101-06-46.00	2101-01-46.00	on request			
1/4 NPTF		-		26	15	14	2101-06-47.00	2101-01-47.00	2701-06-47.10			
7/16-20 UNF	Form E	20	63 MPa	29	9	17	2101-06-21.00	2101-01-21.00	on request			
9/16-18 UNF		35		28	10	19	2101-06-53.00	2101-01-53.00	on request			
ISO 7/-R 1/8	Form C	-	40 MPa	26	12	14	2101-06-40.00	2101-01-40.00	on request			

* M 8 x 1 – please do not use for new constructions.

Option

For FKM (Viton) - Exchange end digits from 00 to 10

10

Other materials, further options, sealing and screw-in threads on request.
We reserve the right to carry out technical modifications.

MINIMESS®-1215 Test Points

Metric DKO, Tee Adaptors-1215

For solder free screw-in pipe connections according to DIN 2353; execution free-cutting steel 1.0718; sealing NBR

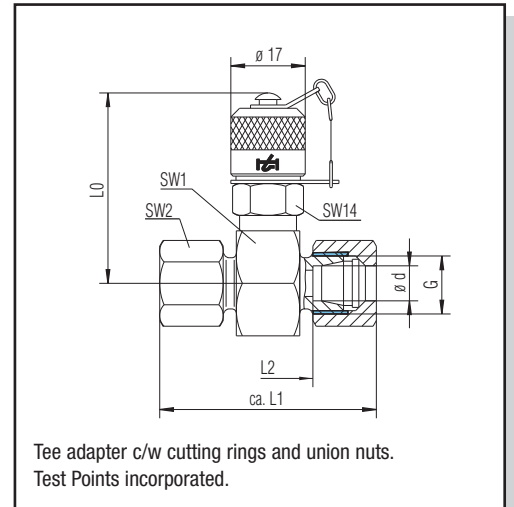
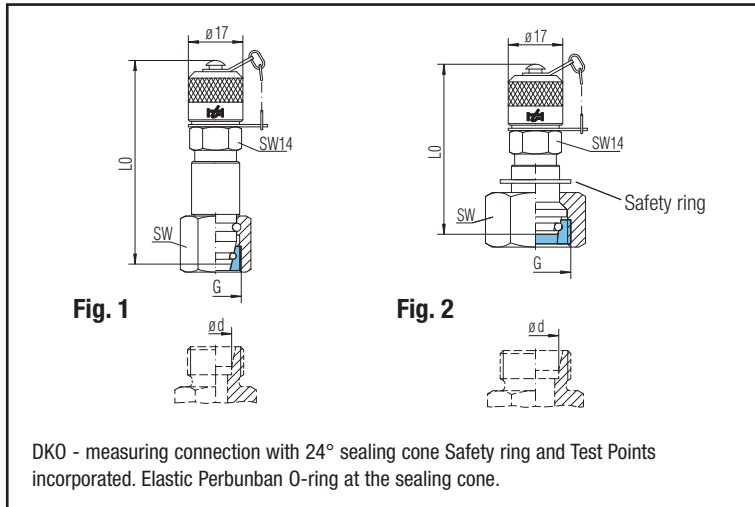

Series Ø d	p max	Thread G
L 6	31,5 MPa	M 12 x 1,5
L 8		M 14 x 1,5
L 10		M 16 x 1,5
L 12		M 18 x 1,5
L 15		M 22 x 1,5
L 18	16 MPa	M 26 x 1,5
L 22		M 30 x 2
L 28		M 36 x 2
L 35		M 45 x 2
L 42		M 52 x 2

Fig.	L ₀	SW	Part-number
1	62	17	2101-40-06.90
	62	19	2101-40-08.90
	62	19	2101-40-10.90
	58	22	2101-40-12.90
	51,5	27	2101-40-15.90
2	52,5	32	2101-40-18.90
	52,5	36	2101-40-22.90
	53,5	41	2101-40-28.90
	55,5	50	2101-40-35.90
	55,5	60	2101-40-42.90

L ₁	L ₂	L ₀	SW ₁	SW ₂	Part-number
50,5	20,5	42	24	14	2101-11-06.90
50,5	20,5	42	24	17	2101-11-08.90
52,5	22,5	42	24	19	2101-11-10.90
52,5	22,5	42	24	22	2101-11-12.90
54,5	24,5	45	30	27	2101-11-15.90
56,5	23,5	46	32	32	2101-11-18.90
60,5	27,5	48	36	36	2101-11-22.90
60,5	27,5	50,5	41	41	2101-11-28.90
68,5	25,5	53	46	50	2101-11-35.90
70,5	24,5	57,5	55	60	2101-11-42.90

Series Ø d	p max	Thread G
S 6	63 MPa	M 14 x 1,5
S 8		M 16 x 1,5
S 10		M 18 x 1,5
S 12		M 20 x 1,5
S 14		M 22 x 1,5
S 16	40 MPa	M 24 x 1,5
S 20		M 30 x 2
S 25		M 36 x 2
S 30		M 42 x 2
S 38		31,5 MPa

Fig.	L ₀	SW	Part-number
1	62	17	2101-41-06.90
	62	19	2101-41-08.90
	62	22	2101-41-10.90
	58	24	2101-41-12.90
	55	27	2101-41-14.90
2	55	30	2101-41-16.90
	55,5	36	2101-41-20.90
	57	46	2101-41-25.90
	58,5	50	2101-41-30.90
	61,5	60	2101-41-38.90

L ₁	L ₂	L ₀	SW ₁	SW ₂	Part-number
54,5	24,5	42	24	17	2101-12-06.90
54,5	24,5	42	24	19	2101-12-08.90
56,5	23,5	42	24	22	2101-12-10.90
56,5	23,5	42	24	24	2101-12-12.90
62,5	26,5	43,5	27	27	2101-12-14.90
62,5	25,5	45	30	30	2101-12-16.90
68,5	25,5	48	36	36	2101-12-20.90
74,5	26,5	50,5	41	46	2101-12-25.90
80,5	27,5	53	46	50	2101-12-30.90
91	29	57,5	55	60	2101-12-38.90

Options

All sealing made of Viton with metal cap (when ordering, exchange end digits from 00 to 10)	00
With mounted plastic cap (when ordering, exchange end digits from 00 to 90)	95

Other materials, further options, sealing and screw-in threads on request.

MINIMESS®-1215 Test Points 1215 Bulkhead Adaptors

For solder free screw-in pipe connections according to DIN 2353; execution free-cutting steel 1.0718; sealing NBR

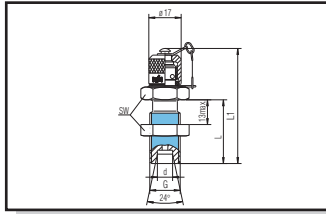

Thread G	p max	Connection	L in mm	L ₁ in mm	SW in mm	Part-number
M 12 x 1,5	31,5 MPa	L 6	34	60,5	17	2101-04-22.90
M 14 x 1,5		L 8	34	60,5	19	2101-04-23.90
M 14 x 1,5	63 MPa	S 6	36	62,5	19	2101-04-24.90

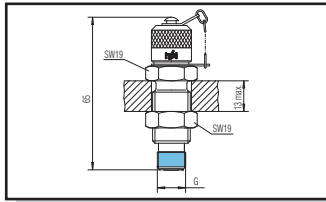

Thread G	p max	Connection	Part-number
Fixing thread 12	63 MPa	On both sides MINIMESS® - 1215 connection	2101-04-16.90

MINIMESS®-1215 pressure gauge connection for bulkhead fitting

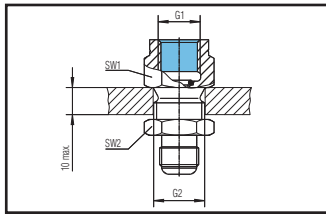

Internal thread G1	p max	Connection G2	L in mm (approx.)	SW in mm	Note	Part-number
ISO 228-G 1/4	63 MPa	1215	31	19	Without return valve	2101-05-11.00
ISO 228-G 1/2			38,5	27		2101-05-12.00
1/4 NPT			-	22		2101-05-23.00

MINIMESS®-pressure gauge – direct connection

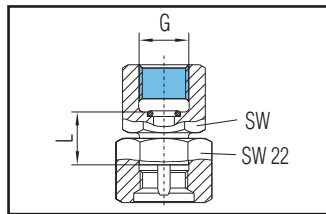

Internal thread G	p max	L in mm	SW in mm	Part-number
ISO 228-G 1/4	63 MPa	14,5	19	2101-07-11.62
ISO 228-G 1/2		17	27	2101-07-12.62
1/4 NPT		-	19	2101-07-23.62

MINIMESS®-1215 Test Points 1215 90° Swivel screw connection

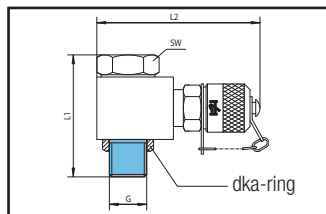

Thread G	p max	L ₁ in mm	L ₂ in mm	SW in mm	Part-number
ISO 228-G 1/4	63 MPa	34,5	46	19	2115-22-14.00

Sealing on screw-in thread (hollow screw) via dka-ring, on hexagon via Gi-ring (NBR). Other options on request.

MINIMESS®-1215 hose adaptors

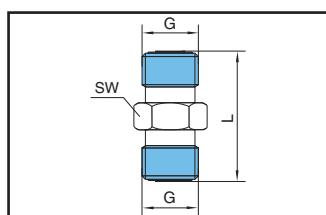



Thread G	p max	L in mm	SW in mm	Note	Part-number
Fixing thread 12	63 MPa	29	14	Without return valve	2146-20-00.20

Other materials, further options, sealing and screw-in threads on request.

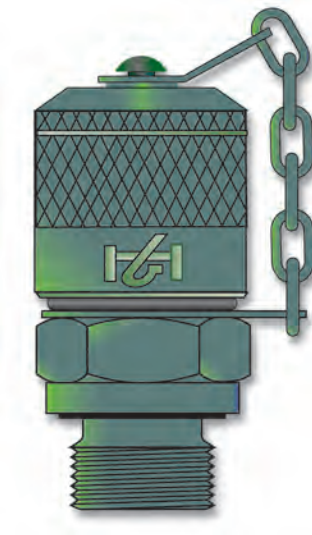
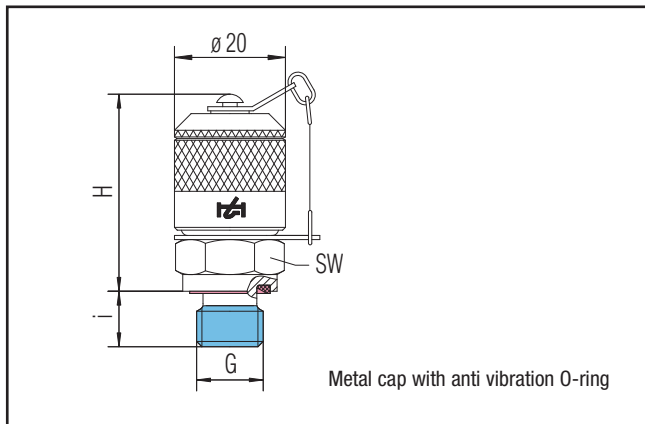
MINIMESS®-1615 Test Points



Thread G	Type of sealing A	Torque in Nm	Technical data				Material: Free cutting steel 1.0718  Metal cap	Part-number with NBR - sealing	Material: Stainless steel 1.4571  Metal cap	Part-number with NBR - sealing
			p max	H in mm	i in mm	SW in mm				
M 10 x 1	Form G	12	63 MPa	37,5	8,5	17	2102-01-33.00	2702-01-33.10		
M 12 x 1,5	Form F	30		36	10	17	2102-01-13.00	on request		
M 14 x 1,5		40		36	10	19	2102-01-14.00	on request		
M 16 x 1,5	Form B	60		36	10	19	2102-01-50.00	on request		
ISO 228-G 1/4	Form F	40		36	10	19	2102-01-18.00	2702-01-18.10		
1/4 NPTF	Form H	-		33	16,5	17	2102-01-47.00	on request		

Option

For FKM (Viton) Exchange end digits from 00 to 10	10
---	-----------

MINIMESS®-1615 Specialised Options

Thread G	Type of sealing	p max	H in mm	L in mm	SW in mm	Execution all sealing made of Viton	Part-number
M 14 x 1,5	Gi-ring	63 MPa	36	12	19	With anti vibration O-ring, alternative housing length	2102-01-14.48
M 14 x 1,5	Gi-ring		36	12	19	With sintered bronze filter	2102-72-14.10

Other materials, further options, sealing and screw-in threads on request.
We reserve the right to carry out technical modifications.

MINIMESS®-1615 Test Points

Metric DKO, Tee Adaptors-1615

For solder free screw-in pipe connections according to DIN 2353; execution free-cutting steel 1.0718; sealing NBR

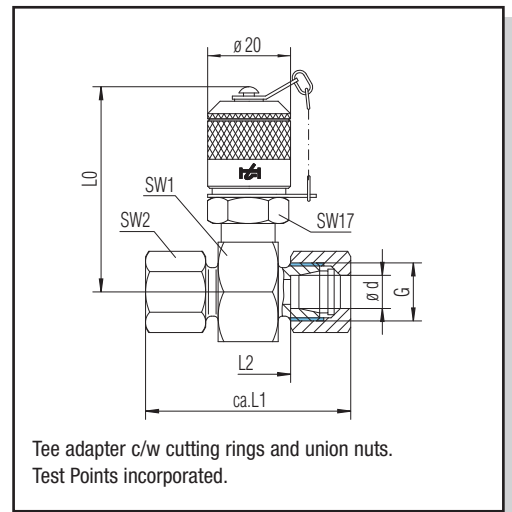
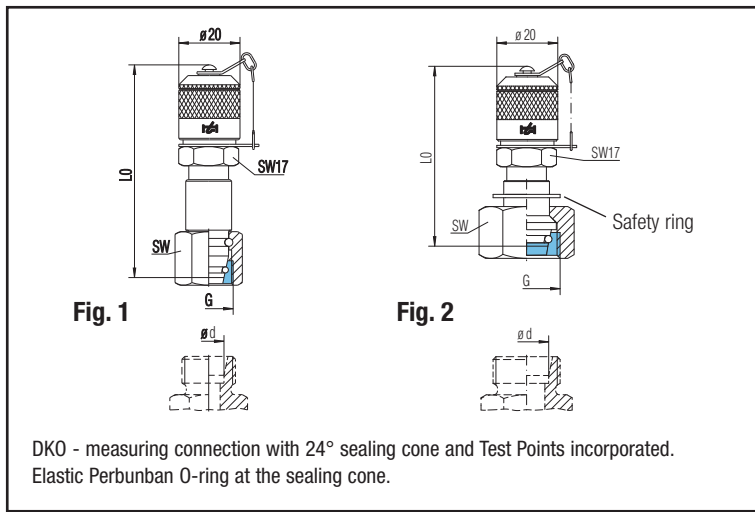

Series Ø d	p max	Thread G
L 6	31,5 MPa	M 12 x 1,5
L 8		M 14 x 1,5
L 10		M 16 x 1,5
L 12		M 18 x 1,5
L 15		M 22 x 1,5
L 18	16 MPa	M 26 x 1,5
L 22		M 30 x 2
L 28		M 36 x 2
L 35		M 45 x 2
L 42		M 52 x 2

Fig.	L ₀	SW	Part-number
1	69,5	14	2102-40-06.00
	69,5	17	2102-40-08.00
	69,5	19	2102-40-10.00
	65,5	22	2102-40-12.00
	59	27	2102-40-15.00
2	60	32	2102-40-18.00
	60	36	2102-40-22.00
	61	41	2102-40-28.00
	63	50	2102-40-35.00
	63	60	2102-40-42.00

L ₁	L ₂	L ₀	SW ₁	SW ₂	Part-number
50,5	20,5	49,5	24	14	2102-11-06.00
50,5	20,5	49,5	24	17	2102-11-08.00
52,5	22,5	49,5	24	19	2102-11-10.00
52,5	22,5	49,5	24	22	2102-11-12.00
54,5	24,5	52,5	30	27	2102-11-15.00
56,5	23,5	53,5	32	32	2102-11-18.00
60,5	27,5	55,5	36	36	2102-11-22.00
60,5	27,5	58	41	41	2102-11-28.00
68,5	25,5	60,5	46	50	2102-11-35.00
70,5	24,5	65	55	60	2102-11-42.00

S 6	63 MPa	M 14 x 1,5
S 8		M 16 x 1,5
S 10		M 18 x 1,5
S 12		M 20 x 1,5
S 14		M 22 x 1,5
S 16	40 MPa	M 24 x 1,5
S 20		M 30 x 2
S 25		M 36 x 2
S 30		M 42 x 2
S 38		31,5 MPa

1	69,5	17	2102-41-06.00
	69,5	19	2102-41-08.00
	69,5	22	2102-41-10.00
	65,5	24	2102-41-12.00
	62,5	27	2102-41-14.00
2	62,5	30	2102-41-16.00
	63	36	2102-41-20.00
	64,5	46	2102-41-25.00
	66	50	2102-41-30.00
	69	60	2102-41-38.00

54,5	24,5	49,5	24	17	2102-12-06.00
54,5	24,5	49,5	24	19	2102-12-08.00
56,5	23,5	49,5	24	22	2102-12-10.00
56,5	23,5	49,5	24	24	2102-12-12.00
62,5	26,5	51	27	27	2102-12-14.00
62,5	25,5	52,5	30	30	2102-12-16.00
68,5	25,5	55,5	36	36	2102-12-20.00
74,5	26,5	58	41	46	2102-12-25.00
80,5	27,5	60,5	46	50	2102-12-30.00
91	29	65	55	60	2102-12-38.00

Option

All sealing made of Viton with metal cap (when ordering, exchange end digits from 00 to 10)

10

Other materials, further options, sealing and screw-in threads on request.

MINIMESS®-1615 Test Points 1615 Bulkhead Adaptors

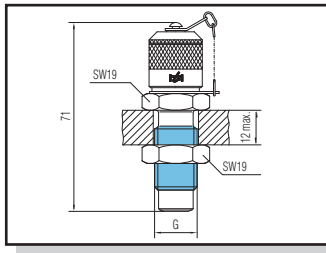

Thread G	p max	Connection	Part-number
M 16 x 1,5	63 MPa	On both sides MINIMESS® 1615 connection	2102-04-01.00

MINIMESS®-1615 pressure gauge connection for bulkhead fitting

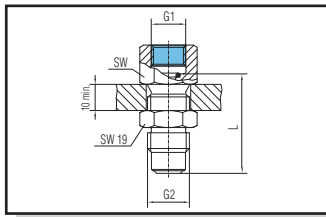

Internal thread G1	p max	Connection G2	L in mm	SW in mm	Note	Part-number
ISO 228-G 1/4	63 MPa	1615 / M 16 x 1,5	38	19	Without return valve	2102-05-11.00
ISO 228-G 1/2			42,5	27		2102-05-12.00

MINIMESS®-1615 pressure gauge – direct connection

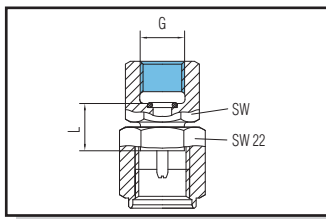

Internal thread G	p max	L in mm	SW in mm	Part-number
ISO 228-G 1/4	63 MPa	14,5	19	2102-07-11.62
ISO 228-G 1/2		17	27	2102-07-12.62
1/4 NPT		–	19	2102-07-23.62

MINIMESS®-1615 Test Points 1615 90° Swivel screw connection

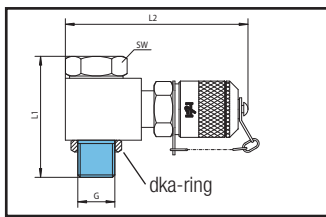

Thread G	p max	L ₁ in mm	L ₂ in mm	SW in mm	Part-number
ISO 228-G 1/4	63 MPa	43	69,5	19	2115-22-24.00

Sealing on screw-in thread (hollow screw) via dka-ring, on hexagon via Gi-ring (NBR).
Other options on request.

MINIMESS®-1615 Hose Adaptors

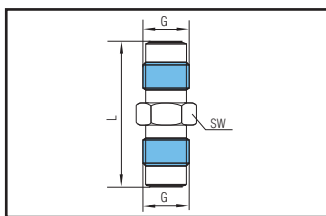

Thread G	p max	L in mm	SW in mm	Note	Part-number
MINIMESS® 1615 M 16 x 1,5	63 MPa	42	17	Without return valve	2146-10-00.00

Other materials, further options, sealing and screw-in threads on request.

MINIMESS®-1604 Test Points

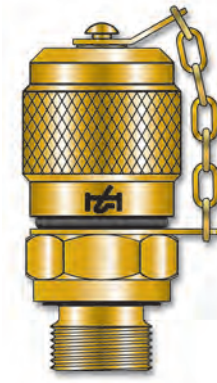
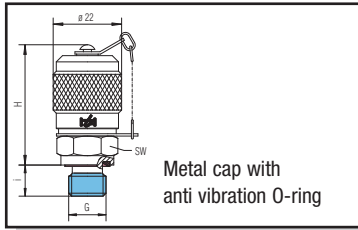

Thread G	Type of sealing A	Torque in Nm	Technical data				Part-number with NBR - sealing
			p max	H in mm	i in mm	SW in mm	
M 10 x 1	Form G	12	40 MPa	43	8,5	17	2106-01-33.00
M 14 x 1,5	Form F	40		40	10	19	2106-01-14.00
ISO 228-G 1/4		40		40	10	19	2106-01-18.00



Material:
Stainless steel
1.4571

Material:
Free cutting steel
1.0718

Part-number with NBR - sealing
on request
on request
2706-01-18.10

Option

For FKM (Viton) Exchange end digits from 00 to 10



10

MINIMESS®-plug-in Test Points

Internal Ball Sealing

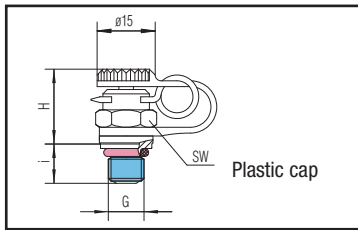

Thread G	Type of sealing A	Torque in Nm	Technical data				Part-number with FKM - sealing
			p max	H in mm	i in mm	SW in mm	
M 8 x 1	Form G	6	40 MPa	17,5	8,5	12	2104-30-32.00
M 10 x 1		12		17,5	8,5	12	2104-30-33.00
ISO 7/ I-R 1/8	Suitable sealant	–		17,5	8,5	12	2104-30-40.00
1/8 NPT		–		17,5	8,5	12	2104-30-43.00



Material:
Stainless steel
1.4571

Part-number with FKM - sealing
2704-30-32.10
on request
on request
on request

MINIMESS®-Pressure inhibitors and accessories

Pressure limiter valve

- Used for protection of pressure gauges against overload

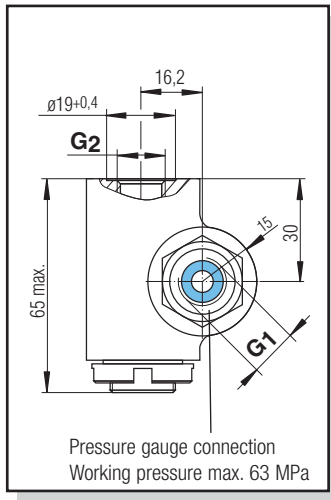

Adjustable pressure range	Pressure gauge connection G 1	Connection G 2	Part-number
0,5 bis 0,9 MPa	ISO 228-G 1/4 according to DIN 16288	ISO 228-G 1/4 according to DIN 3852 Form X	5110-01-20.00
0,1 bis 2,5 MPa			5110-02-20.00
0,25 bis 6,3 MPa			5110-03-20.00
6,3 bis 10 MPa			5110-04-20.00
10 bis 25 MPa			5110-05-20.00
25 bis 60 MPa			5110-07-20.00

0,5 bis 0,9 MPa	ISO 228-G 1/2 according to DIN 16288	ISO 228-G 1/4 according to DIN 3852 Form X	5110-01-30.00
0,1 bis 2,5 MPa			5110-02-30.00
0,25 bis 6,3 MPa			5110-03-30.00
6,3 bis 10 MPa			5110-04-30.00
10 bis 25 MPa			5110-05-30.00
25 bis 60 MPa			5110-07-30.00

Restrictor valve

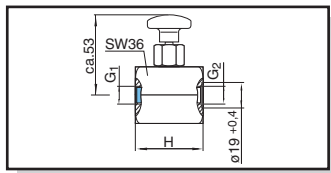

Thread G1	Thread G2	H	p max	Execution	Part-number
ISO 228-G 1/4	ISO 228-G 1/4	53	63 MPa	Adjustable under pressure up to 150 bar in-line connection	5104-03-00.00
ISO 228-G 1/2	ISO 228-G 1/4	58			5104-02-00.00

Damping cartridge (snubber)

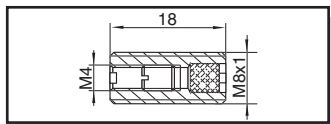

Borehole: nozzle	Material	Application	Part-number
$\varnothing 0,5$ mm	2.0401	Choking element for dampening of fluidity vibrations	2100-24-01.00

Threaded adaptor M 10 x 1, Form G

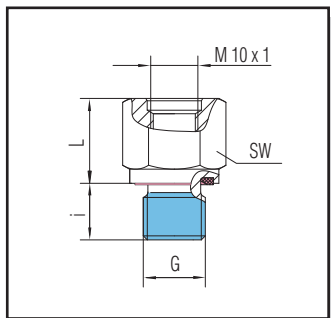

External thread G	Type of sealing	p max	L in mm	i in mm	SW in mm	Part-number
M 12 x 1,5	Form F	63 MPa	19	10	17	2134-13-00.00
ISO 228-G 1/8			19	8	17	2134-07-01.00
ISO 228-G 1/2			10	14	27	2134-21-00.00
ISO 228-G 3/4			13	12	32	2134-51-00.00
1/2 NPTF	Form H		10	18	24	2134-45-01.01

Part-number
Stainless steel 1.4571
auf Anfrage
2734-07-01.10
2734-21-00.10
2734-51-00.10
on request

Welding adapter

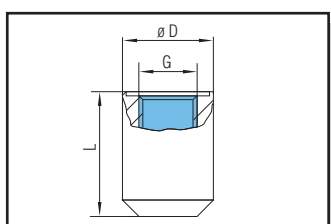

Thread G	Screw-in hole	p max	L in mm	SW in mm	Part-number
M 10 x 1	Form G	63 MPa	25	20	2126-33-00.01
M 14 x 1,5	Form F		30	22	2126-04-00.01
ISO 228-G 1/4					2126-08-00.01

Part-number
Stainless steel 1.4571
on request
on request
2726-08-00.01

Other materials, further executions, sealing and screw-in threads on request.

MINIMESS®-Technical data on DN2 and DN4 microbore hose

DN 2 and DN 4

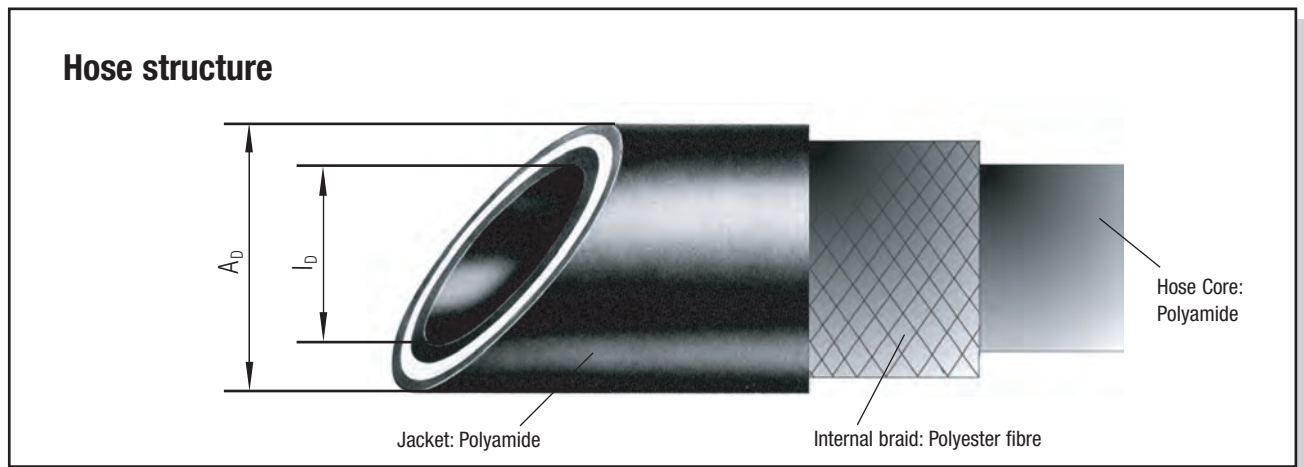

Nominal width	Design	Application	p_n in MPa	p_B in MPa	I_D in mm	A_D in mm	r_{min}	Operable temperature range	Pressure utilisation factor	
DN 2	Standard 400	Perforated hose	40,0	104,0	2	5	20 mm (below -20 °C 30 mm)	-20 °C up to +100 °C short time up to +120 °C	0 °C 122% 30 °C 110%	
DN 2	Standard 630		63,0	195,0	2	5			50 °C 100% 80 °C 86%	
DN 2	Low temperature		63,0	150,0	2	5		-54 °C up to +100 °C	100 °C 77% 120 °C 68%	
DN 4	Standard 315		31,5	81,0	4	8	40 mm (below -20 °C 60 mm)	-20 °C up to +100 °C short time up to +120 °C	Example for calculation: MINIMESS®-hose DN 2/63 MPa at 30 °C pressure utilisation facto: 63,0 x 1,10 = 69,3 MPa	
DN 4	Standard 450		45,0	150,0	4	8				

Reference of the specified data: 20 °C – 3 K

p_n = operating pressure

p_B = bursting pressure

I_D = internal diameter

A_D = external diameter

r_{min} = Minimum bend radius of hose

Perforated hose = Jacket of hose is perforated for applications using gas

Definition for the tightness of a MINIMESS®-hose pipe

“Technically tight” describes systems, part systems and functional elements if the leakage rate amounts to $< 0,00001 \text{ mbar l s}^{-1}$.

Criteria for selection of hoses and fittings

1. Selection of the hose assembly for the maximum operating pressure (p_n):

When ordering a hose assembly, you have to pay attention to the operating pressures of the hose material and of the connection fitting. The lowest pressure determines the max. operating pressure of the complete hose assembly.

2. Selection of hose assembly for use with different media:

Hose assemblies can be used with different media, as long as the end connections are suitable. To check the compatibility for different media, please refer to our list on page 37.

If your medium is not mentioned on page 37, please contact us!

Fittings available with the following materials:

Free cutting steel 1.0718 galvanized and chromated, acid-resistant stainless steel 1.4571 (antimagnetic)

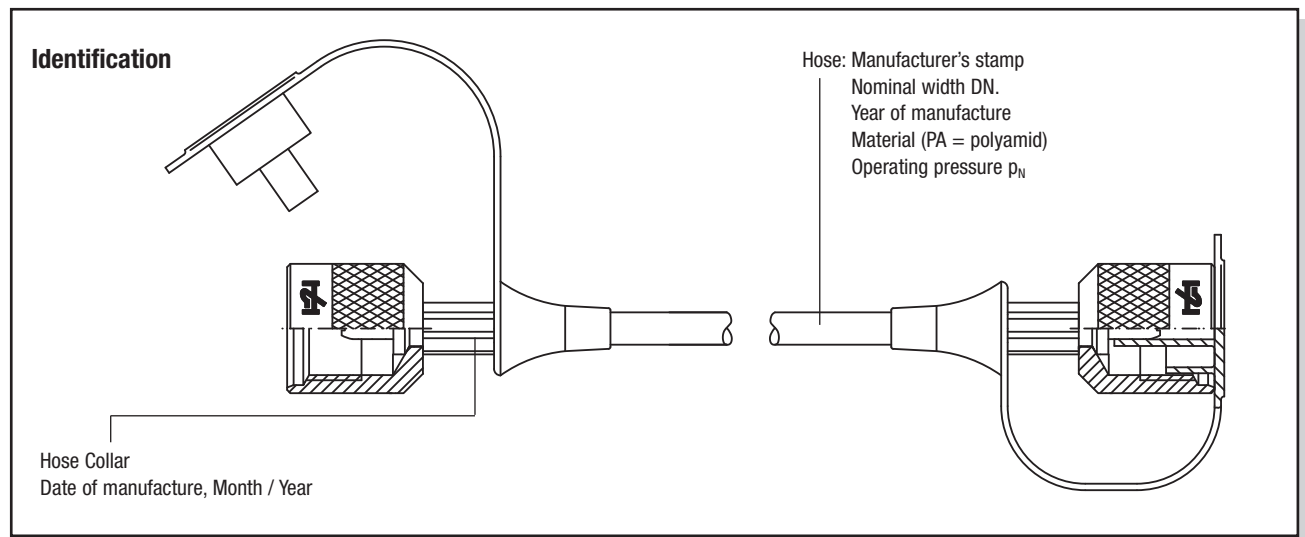

Safety note: The hose assemblies have to be protected from flames and sharp-edged, hot objects.

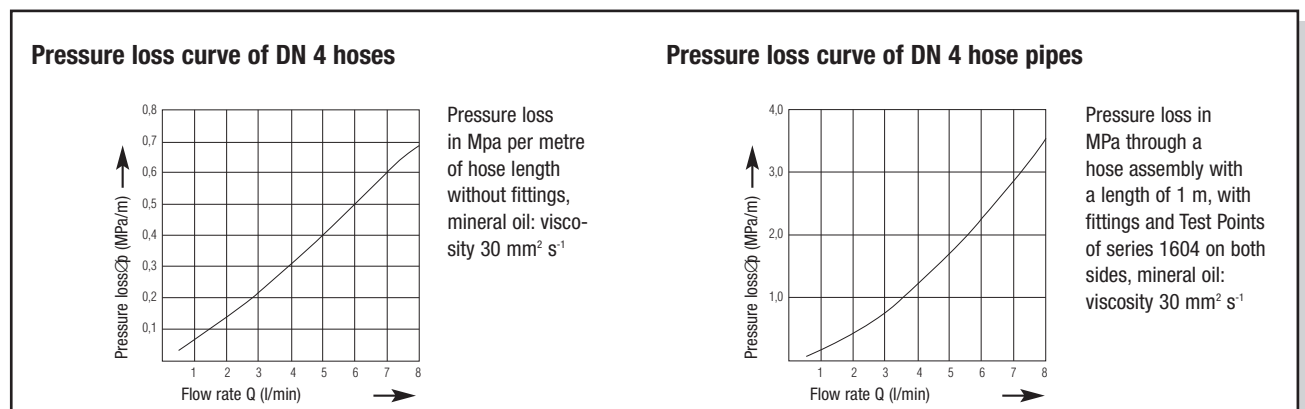
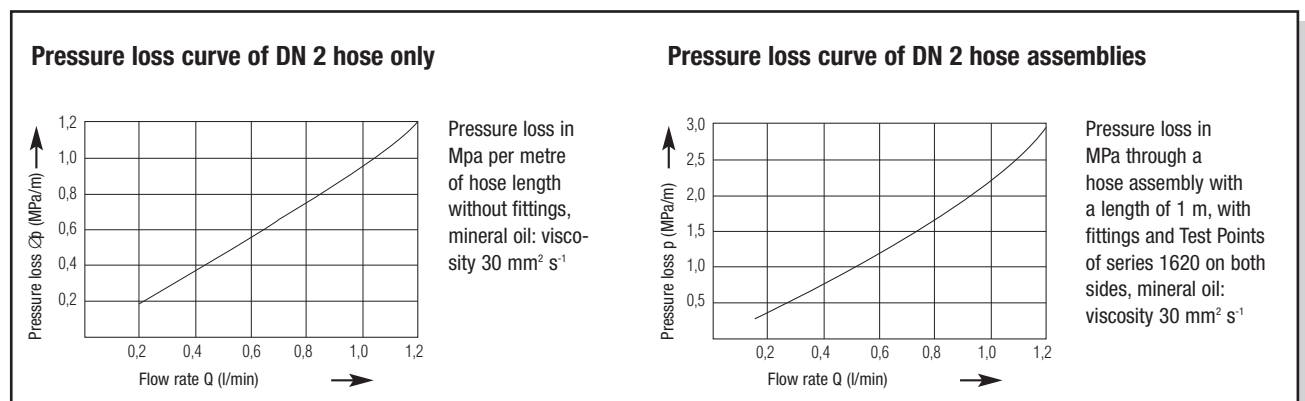

We guarantee a very high quality level of our MINIMESS®-systems, as all components are manufactured very precisely and to tight tolerances. All parts in our MINIMESS®-system are easy and safe to use. We reserve the right to carry out technical modifications!

Mounting suggestions of MINIMESS®-hose assemblies

Working reliability of a system and lifetime of the hose assembly are dependent on the correct installation. For this, here are some important notes:

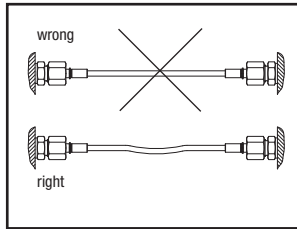

Under load, the length of a hose pipe can change. A shortening causes an additional tensile stress of the hose and the connections. Therefore, the hose pipe needs “slack” in an unpressurised state. Please tighten the union nuts only so far using recommended tightening torques. Further tightening does not improve the operation, but can damage the connections.

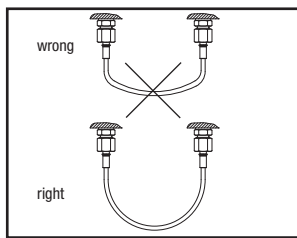

With curved assemblies, attention has to be paid to the bending radius. Sharp bends have to be avoided wherever possible. When calculating the length of a hose assembly, you have to pay attention to the fact that the connection fittings are not flexible. The correct calculation of the free hose length between the fittings is therefore essential.

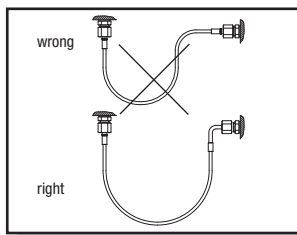

90° hose fittings are also available to aid in the fitting of hose assemblies to maximize life and operation of the assembly.

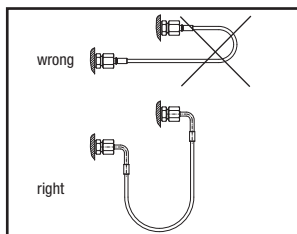

90° hose fittings can also aid in the fitting of a tidy hose assembly in the tightest of porting requirements.

Notes for operation and installation

In order to guarantee the operability of hoses and to not reduce assembly life by introducing additional strains, the following points have to be taken into consideration:

- Hose assemblies may not be strained during operation by external influences like tension, torsion and upset.
- The smallest mentioned bending radius of the hose must not be exceeded at any time.
- Hose assemblies have to be protected against external damages caused by thermal, chemical or mechanical influences.
- Painting or marking of hose assemblies should be avoided.

Notes for storage of hose and hose assemblies

- Store in cool, dry places and avoid direct UV-irradiation.
- Sources of radiant heat should be avoided.
- Ozone building light fittings and electronic instruments with sparking should be kept away from hoses and hose material (e.g. mercury vapor discharge lamps)
- Optimum storage conditions are temperatures between +15°C and +25°C, a relative air humidity of 65%, as well as shielding against UV-radiation by special UV-impervious foils.
- The storage time should not exceed four years for hose and two years for hose assemblies.

MINIMESS®-DN 2 microbore hose assemblies

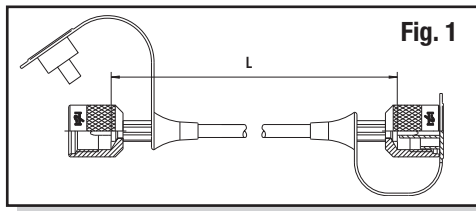

For 1620, 1615, 1215 and plug-in series



The tables show the series 1620

- Suitable for hydraulic and other oils on mineral oil basis
- Same fittings on both sides
- Fittings made of free cutting steel 1.0718

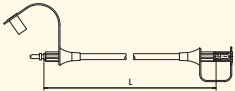
L	p max	Part-number	p max	Part-number
200	40 MPa	S 100-AC-AC-0020	63 MPa	S 110-AC-AC-0020
300		S 100-AC-AC-0030		S 110-AC-AC-0030
400		S 100-AC-AC-0040		S 110-AC-AC-0040
500		S 100-AC-AC-0050		S 110-AC-AC-0050
630		S 100-AC-AC-0063		S 110-AC-AC-0063
800		S 100-AC-AC-0080		S 110-AC-AC-0080
1000		S 100-AC-AC-0100		S 110-AC-AC-0100
1250		S 100-AC-AC-0125		S 110-AC-AC-0125
1500		S 100-AC-AC-0150		S 110-AC-AC-0150
2000		S 100-AC-AC-0200		S 110-AC-AC-0200
2500		S 100-AC-AC-0250		S 110-AC-AC-0250
3200		S 100-AC-AC-0320		S 110-AC-AC-0320
4000		S 100-AC-AC-0400		S 110-AC-AC-0400
5000		S 100-AC-AC-0500		S 110-AC-AC-0500

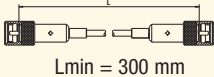
Fittings made of stainless steel 1.4571 	Exchange number 1 to 7, when ordering	7	7
Series 1215 (picture 1) (fixing thread)	When ordering, replace the letter codes with -AA-AA-.	-AA-AA-	
Series 1615 (picture 1) (M 16 x 1,5)	When ordering, replace the letter codes with -AB-AB-.	-AB-AB-	
Plug-in series Max. pressure 40,0 MPa	When ordering, replace the letter codes with -AI-AI-.	-AI-AI-	
DN 2 measuring hoses with protection against leakage with integrated return valve			
Series 1620 (M 16x2) 	When ordering, replace both letter codes with -AR-AR-.	-AR-AR-	

MINIMESS®-DN 4 microbore hose assemblies 1604

for series 1604

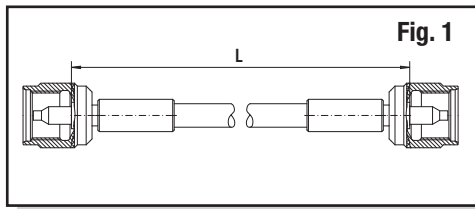

- Suitable for hydraulic and other oils on mineral oil basis
- Same fittings on both sides
- Fittings made of free cutting steel 1.0718

L	p max	Part-number	p max	Part-number
200	31,5 MPa	S 150-AD-AD-0020	45 MPa	S 160-AD-AD-0020
300		S 150-AD-AD-0030		S 160-AD-AD-0030
400		S 150-AD-AD-0040		S 160-AD-AD-0040
500		S 150-AD-AD-0050		S 160-AD-AD-0050
630		S 150-AD-AD-0063		S 160-AD-AD-0063
800		S 150-AD-AD-0080		S 160-AD-AD-0080
1000		S 150-AD-AD-0100		S 160-AD-AD-0100
1250		S 150-AD-AD-0125		S 160-AD-AD-0125
1500		S 150-AD-AD-0150		S 160-AD-AD-0150
2000		S 150-AD-AD-0200		S 160-AD-AD-0200
2500		S 150-AD-AD-0250		S 160-AD-AD-0250
3200		S 150-AD-AD-0320		S 160-AD-AD-0320
4000		S 150-AD-AD-0400		S 160-AD-AD-0400
5000		S 150-AD-AD-0500		S 160-AD-AD-0500

Armaturen aus stainless steel 1.4571  Exchange number 1 to 7, when ordering

7

7



DN 4 measuring hoses with protection against leakage with integrated return valve

Series 1604 (fixing thread 16)  When ordering, replace both letter codes with -AY-AY-.

-AY-AY-  -AY-AY-
Lmin = 300 mm

Delivery effects with protective plugs on both sides.

Order chart for hose material and accessories DN 2 and DN 4

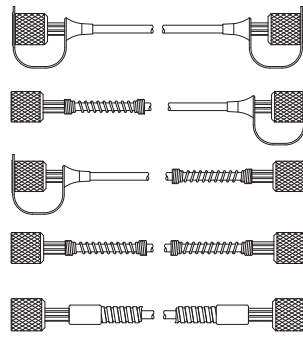
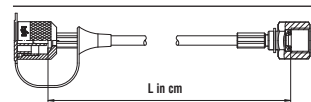
Options		Part-number S XXX - XX - XX - XXXX			
Material of the fittings					
Free cutting steel 1.0718 galvanized and chromated		1			
Free cutting steel 1.0718 plus sealing for brake fluid		2			
Acid-resistant stainless steel 1.4571 		7			
Hose material DN 2					
Perforated standard hose	40,0 MPa	 DN 2	0		
Perforated standard hose	63,0 MPa		1		
Perforated low temperature hose	63,0 MPa		2		
Hose material DN 4					
Perforated standard hose	31,5 MPa	 DN 4	5		
Perforated standard hose	45,0 MPa		6		
Standard			0		
Additional options					
Anti buckling spiral, left side (min. hose length 40 cm)			1		
Anti-buckling spiral, right side (min. hose length 40 cm)			2		
Anti-buckling spiral both sides (min. hose length 40 cm)			3		
Aluminium protection hose (min. hose length 40 cm)		4			
Freely selectable fitting Input as a 2-digit fitting code from page 27 on					
Freely selectable fitting Input as a 2-digit fitting code from page 27 on					
Length L in cm (e.g. 30 cm = 0030 or 500 cm = 0500) Input as a 4-digit group of figures					

Attention: Aluminium protection in combination with an anti-buckling spiral is not possible.

Selectable hose ends for DN 2 and DN 4 hose

Free cutting steel 1.0718 galvanized and chromated

MINIMESS®-connection

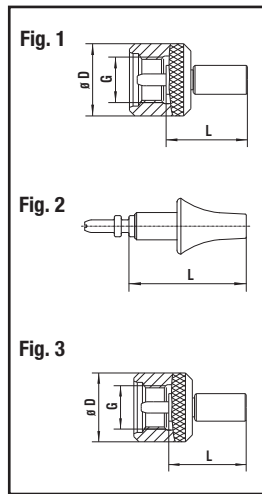

Fittings	Part-number	Fig.	Thread G	p max in MPa	ø D in mm	L	Fitting code
DN 2	2119-02-00.00	1	1215	63	20	22	AA
	2119-03-00.00	1	1615	63	20	20	AB
	2119-04-00.00	1	1620	63	20	20	AC
	2119-21-00.00	2	Plug-in	40	–	30,5	AI

DN 4	2119-05-00.00	3	1215	63	20	35	AA
	2119-06-00.00	3	1615	63	20	35	AB
	2119-07-00.00	3	1620	63	20	35	AC
	2119-14-00.00	3	1604	40	22	35	AD

MINIMESS®-connection 90°

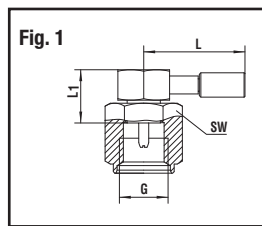

Fittings	Part-number	Fig.	Thread G	p max in MPa	SW	L	L ₁	Fitting code
DN 2	2119-02-01.00	1	1215	63	22	35,5	17,5	AJ
	2119-03-01.00		1615	63	22	35,5	17,5	AK
	2119-04-01.00		1620	63	22	35,5	17,5	AL

MINIMESS®-connection with non-return valve

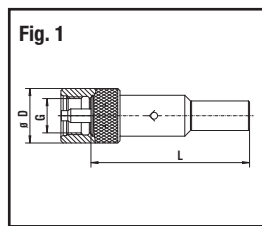

Fittings	Part-number	Fig.	Thread G	p max in MPa	ø D in mm	L	Fitting code
DN 2	2119-04-04.00	1	1620	63	20	50	AR

DN 4	2119-09-04.00	1	1604	40	24	70	AY
------	---------------	---	------	----	----	----	----

MINIMESS®-connection with hexagon clamping nut

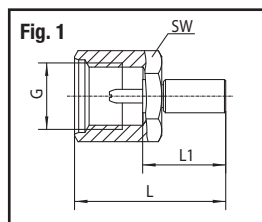

Fittings	Part-number	Fig.	Thread G	p max in MPa	SW	L	L ₁	Fitting code
DN 2	2119-02-03.00	1	1215	63	19	38	22	AM
	2119-03-03.00		1615	63	19	38	20	AN
	2119-04-03.00		1620	63	19	38	20	AO

Pressure gauge connection according to DIN 16 288 with O-ring sealing

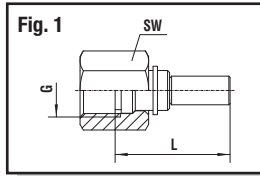

Fittings	Part-number	Fig.	Thread G	p max in MPa	SW in mm	L	L ₁	Fitting code
DN 2	5140-20-21.00	1	ISO 228-G 1/4	63	17	28,5	–	FG
	5140-20-22.00		ISO 228-G 1/2	63	27	31,5	–	FH

Pressure gauge connection according to DIN 16 288 - 90° with O-ring sealing

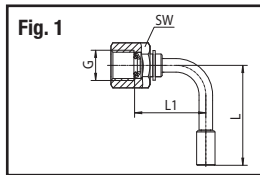

Fittings	Part-number	Fig.	Thread G	p max in MPa	SW in mm	L	L ₁	Fitting code
DN 2	5140-20-23.00	1	ISO 228-G 1/4	63	17	43,5	32	FI
	5140-20-24.00		ISO 228-G 1/2	63	27	43	43	FJ

DKO - connection “light (L) and heavy (S) series” for solder free screw-in pipe connections according to DIN 2353 (24°)

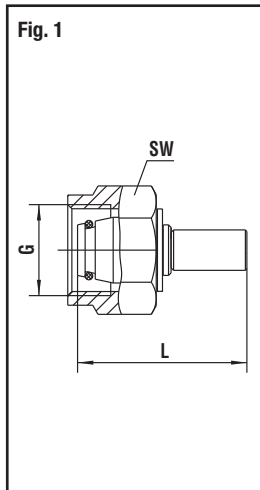

Fittings	Part-number	Fig.	Series	Thread G	p max in MPa	SW in mm	L	Fitting code
DN 2	5140-06-03.00	1	L 6	M 12 x 1,5	31,5	14	30	CQ
	5140-06-04.00		L 8	M 14 x 1,5	31,5	17	34	CR
	5140-06-07.00		L 10	M 16 x 1,5	31,5	19	33,5	CS
	5140-06-08.00		L 12	M 18 x 1,5	31,5	22	33,5	CT

DN 2	5140-06-01.00	1	S 6	M 14 x 1,5	63	17	30	CU
	5140-06-02.00		S 8	M 16 x 1,5	63	19	34	CV
	5140-06-05.00		S 10	M 18 x 1,5	63	22	33,5	CW
	5140-06-06.00		S 12	M 20 x 1,5	63	24	23,5	CX

DN 4	5140-16-03.00	1	L 6	M 12 x 1,5	31,5	14	40	CQ
	5140-16-04.00		L 8	M 14 x 1,5	31,5	17	41	CR
	5140-16-07.00		L 10	M 16 x 1,5	31,5	19	44,5	CS
	5140-16-08.00		L 12	M 18 x 1,5	31,5	22	44,5	CT

DN 4	5140-16-01.00	1	S 6	M 14 x 1,5	63	17	40	CU
	5140-16-02.00		S 8	M 16 x 1,5	63	19	41	CV
	5140-16-05.00		S 10	M 18 x 1,5	63	22	44,5	CW
	5140-16-06.00		S 12	M 20 x 1,5	63	24	44,5	CX

**DKO - connection “light (L) and heavy (S) series” 90°
for solder free screw-in pipe connections according to DIN 2353 (24°)**

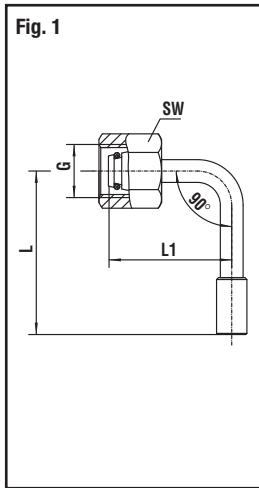

Fittings	Part-number	Fig.	Series	Thread G	p max in MPa	SW in mm	L	L ₁	Fitting code
DN 2	5140-06-13.00	1	L 6	M 12 x 1,5	31,5	14	30	32,5	DA
	5140-06-18.00		L 8	M 14 x 1,5	31,5	17	34	32,5	DB
	5140-06-10.00		L 10	M 16 x 1,5	31,5	19	33,5	37,5	DC
	5140-06-17.00		L 12	M 18 x 1,5	31,5	22	33,5	37,5	DD
DN 2	5140-06-15.00	1	S 6	M 14 x 1,5	63	17	30	32,5	DE
	5140-06-19.00		S 8	M 16 x 1,5	63	19	34	32,5	DF
	5140-06-14.00		S 10	M 18 x 1,5	63	22	33,5	37,5	DG
	5140-06-16.00		S 12	M 20 x 1,5	63	24	23,5	37,5	DH

Standpipes for solder free screw-in pipe connection according to DIN 2353

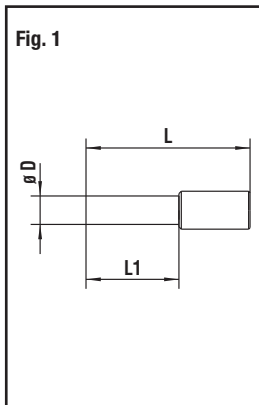

Fittings	Part-number	Fig.	Execution	p max in MPa	ø D in mm	L	L ₁	Fitting code
DN 2	5140-08-16.00	1	straight	10	4	35	20	BA
	5140-08-01.00			63	6	35	20	BB
	5140-08-11.00			63	8	35	21	BC
	5140-07-01.00			63	6,35	35	20	BD
DN 4	5140-18-01.00	1	straight	63	6	48	20	BB
	5140-18-02.00			45	8	47	21	BC

Standpipes, 90°, for solder free screw-in pipe connection acc. to DIN 2353

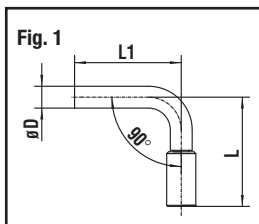

Fittings	Part-number	Fig.	Execution	p max in MPa	ø D in mm	L	L ₁	Fitting code
DN 2	5140-08-02.00	1	90°	63	6	30	28	BG
DN 4	5140-08-12.00	1	90°	63	6	48	25	BG

Male threaded connection

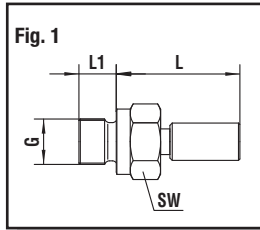

Fittings	Part-number	Fig.	Thread G	p max in MPa	SW in mm	L	L ₁	Fitting code
DN 2	5140-24-03.00	1	ISO 228-G 1/8	40	14	26,5	8	GA

ORS-connection

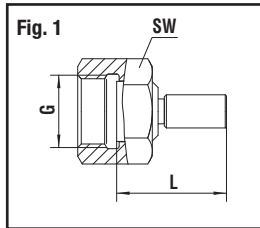

Fittings	Part-number	Fig.	Thread G	p max in MPa	SW in mm	L	L ₁	Fitting code
DN 2	5140-26-03.00	1	11/16-16UN	40	22	26,5	-	HC

Banjo fitting with M10x1 Banjo Bolt

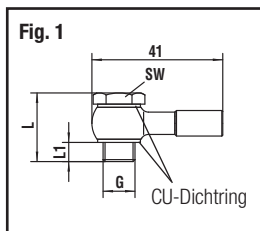

Fittings	Part-number	Fig.	Thread G	p max in MPa	SW in mm	L	L ₁	Fitting code
DN 2	5140-27-01.00	1	M 10 x 1	20	14	28	10	IA

Banjo fitting to accept M10x1 Banjo Bolt according to DIN 7642

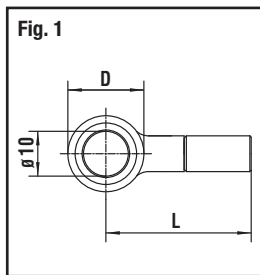

Fittings	Part-number	Fig.		p max in MPa	SW in mm	L	D	Fitting code
DN 2	5140-27-02.00	1	-	20	-	41	17	IB
DN 4	5140-27-11.00	1	-	20	-	43,5	17	IB

MINIMESS®-hoses

Accessories

Hose material DN 2 and DN 4

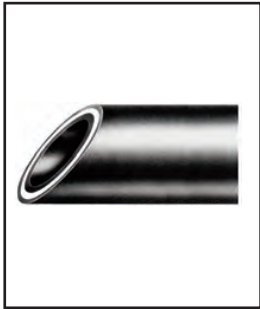

Hose material for self assembly		Part-number
Perforated hose, DN 2	40,0 MPa	2020-01-00.31
Perforated hose, DN 2	63,0 MPa	2020-01-00.30
Low temperature, Perforated hose, DN 2	63,0 MPa	2020-01-00.18
Perforated hose, DN 4		31,5 MPa
Perforated hose, DN 4		45,0 MPa
		2030-01-00.22
		2030-01-00.24

Anti-buckling spiral

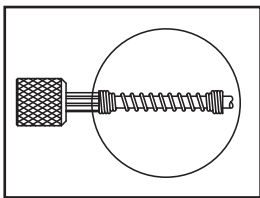

Anti-buckling spiral for self assembly		Part-number
Anti-buckling spiral for DN 2		2123-01-00.01
Anti-buckling spiral for DN 4		2133-01-00.01

Aluminium protection hose

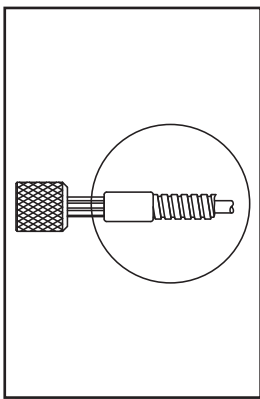

Aluminium protection hose for self assembly		Part-number
Aluminium protection hose DN 2 In addition to this, 2 pieces end screw sockets are necessary		2121-01-00.01
End screw sockets DN 2		2121-01-00.02
Aluminium protection hose for self assembly		Part-number
Aluminium protection hose DN 4 In addition to this, 2 pieces end screw sockets are necessary		2131-01-00.01
End screw sockets DN 4		2131-01-00.02

Digital pressure gauges

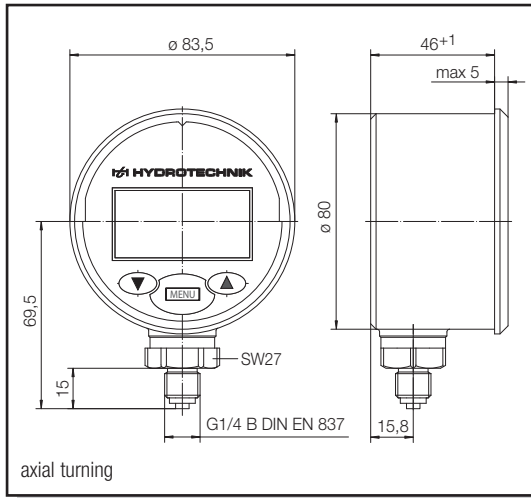

Technical data

- Measuring range: 0 to 60 bar, 0 to 250 bar or 0 to 600 bar
- Accuracy: $\pm 0,5\%$ F.S., ± 1 digit
- Wandlungsrate: 5/s
- 4-digit, 7-segment LCD display, 11 mm height, additional bargraph with 10 segments scale
- Proof pressure, 2.0x, 1000 bar max.
- Units: MPa, PSI and bar
- Pressure peak: min.- and max.-values
- Protection type: IP 65 acc. to EN 60529 / IEC 529
- Housing: stainless steel
- 2 x 1,5 V battery type AA, 4000 h
- Weight: approx. 0,4 kg



Digital Pressure gauge are the best solution to carry out a local network independent pressure measurement.

Accuracy, reliability and mechanical capacity make the digital pressure gauge perfect for carrying out different pressure measurements.

Axial turning of the case for better reading. Simple operation is carried out with a 3 button panel whereby pressure and pressure peaks can also be measured as well as min. and max. values.

Measuring range	Part-number
0–60 bar	9801-99-00.60
0–250 bar	9801-99-02.50
0–600 bar	9801-99-06.00

MINIMESS®-pressure test kit with two digital pressure gauges



Test kit, one digital pressure gauge		Part-number
Measuring range	Identification	3101 - 86 - 0 X.50 4, 6 or 9
0–60 bar	4	
0–250 bar	6	
0–600 bar	9	

Test kit, two digital pressure gauges		Part-number
Measuring range	Identification	3101 - 87 - X X.50 Lower measuring range Higher measuring range
0–60 bar	4	
0–250 bar	6	
0–600 bar	9	

Analogue pressure gauges

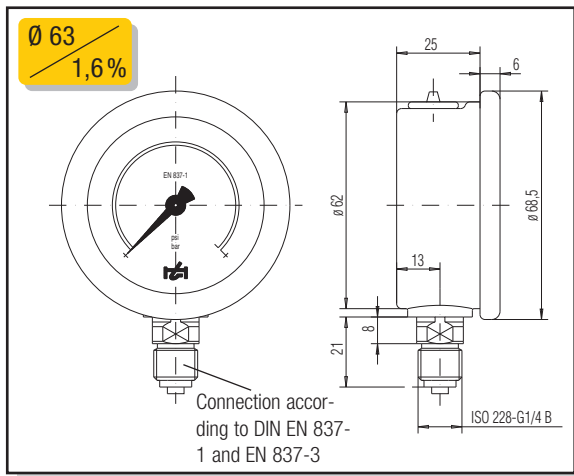

- Housing \varnothing 63 mm/Stainless steel
- Accuracy 1,6% of end value
- Display range in bar and psi
- Glycerine filled

Display range	Part-number
0–10 bar (0–145 psi)	9802-01-00.10
0–16 bar (0–230 psi)	9802-01-00.16
0–25 bar (0–360 psi)	9802-01-00.25
0–40 bar (0–580 psi)	9802-01-00.40
0–60 bar (0–870 psi)	9802-01-00.60
0–100 bar (0–1450 psi)	9802-01-01.00
0–160 bar (0–2300 psi)	9802-01-01.60
0–250 bar (0–3600 psi)	9802-01-02.50
0–400 bar (0–5800 psi)	9802-01-04.00
0–600 bar (0–8700 psi)	9802-01-06.00

MINIMESS®-1620 pressure test kit with two analogue pressure gauges



Test kit with 2 digital pressure gauges		Part-number
Measuring range	Identification	3101 - 14 - X X.50
0–10 bar (0–145 psi)	0	<p>Smaller measuring range</p> <p>Larger measuring range</p> <p>Requested measuring range</p>
0–16 bar (0–230 psi)	1	
0–25 bar (0–360 psi)	2	
0–40 bar (0–580 psi)	3	
0–60 bar (0–870 psi)	4	
0–100 bar (0–1450 psi)	5	
0–160 bar (0–2300 psi)	6	
0–250 bar (0–3600 psi)	7	
0–400 bar (0–5800 psi)	8	
0–600 bar (0–8700 psi)	9	
Test kit with 1 digital pressure gauge		3101 - 13 - 0 X.50

MINIMESS®-pressure test kit for series 1215 When ordering, please exchange end digits to 30

30

MINIMESS®-pressure test kit for series 1615 When ordering, please exchange end digits to 40

40

Analogue pressure gauges

Rear Entry

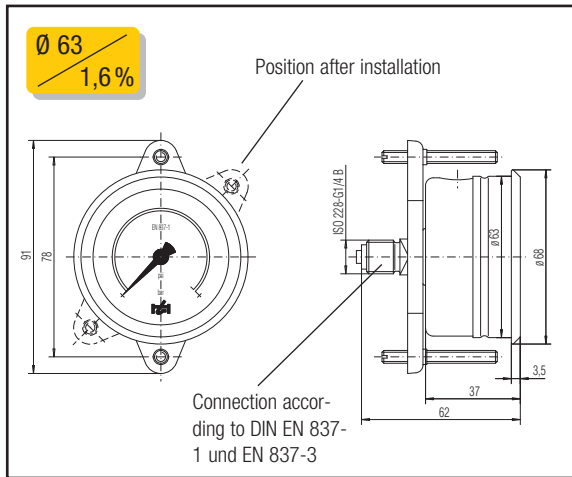

Display range	Part-number
0–10 bar (0–145 psi)	9801-53-00.10
0–16 bar (0–230 psi)	9801-53-00.16
0–25 bar (0–360 psi)	9801-53-00.25
0–40 bar (0–580 psi)	9801-53-00.40
0–60 bar (0–870 psi)	9801-53-00.60
0–100 bar (0–1450 psi)	9801-53-01.00
0–160 bar (0–2300 psi)	9801-53-01.60
0–250 bar (0–3600 psi)	9801-53-02.50
0–400 bar (0–5800 psi)	9801-53-04.00
0–600 bar (0–8700 psi)	9801-53-06.00

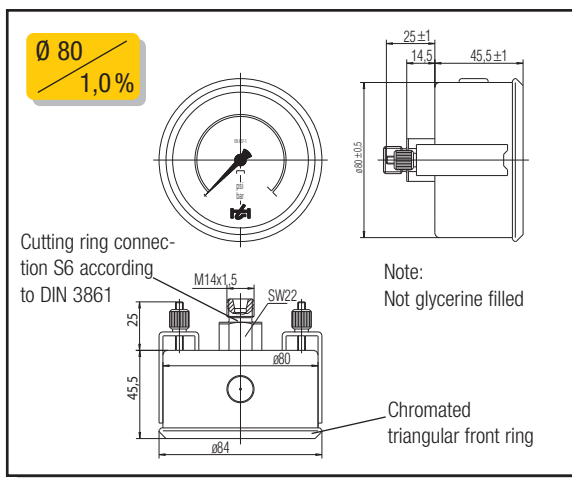

Display range	Part-number
0–10 bar (0–145 psi)	9801-35-00.10
0–16 bar (0–230 psi)	9801-35-00.16
0–25 bar (0–360 psi)	9801-35-00.25
0–40 bar (0–580 psi)	9801-35-00.40
0–60 bar (0–870 psi)	9801-35-00.60
0–100 bar (0–1450 psi)	9801-35-01.00
0–160 bar (0–2300 psi)	on request
0–250 bar (0–3600 psi)	9801-35-02.50
0–400 bar (0–5800 psi)	9801-35-04.00
0–600 bar (0–8700 psi)	9801-35-06.00

- Housing \varnothing 63 mm or \varnothing 80 mm / Stainless steel
- Accuracy: 1,6% or 1,0% of end value
- Display range in bar and psi
- Glycerine filled

Analogue pressure gauges

Bottom Entry

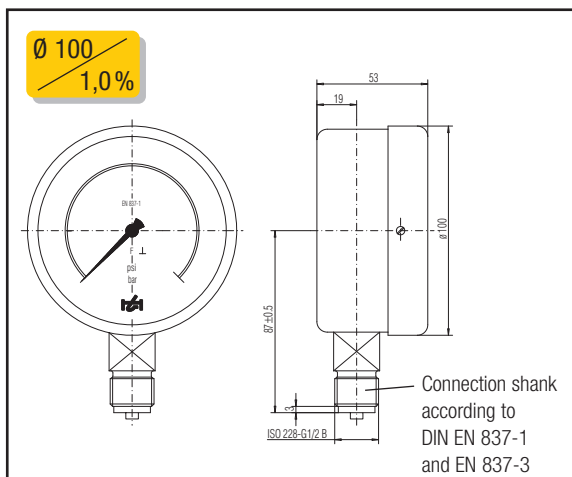

Display range	Part-number
0–10 bar (0–145 psi)	on request
0–16 bar (0–230 psi)	on request
0–25 bar (0–360 psi)	9801-20-00.25
0–40 bar (0–580 psi)	on request
0–60 bar (0–870 psi)	9801-20-00.60
0–100 bar (0–1450 psi)	9801-20-01.00
0–160 bar (0–2300 psi)	9801-20-01.60
0–250 bar (0–3600 psi)	on request
0–400 bar (0–5800 psi)	9801-20-04.00
0–600 bar (0–8700 psi)	9801-20-06.00

Accumulator charging and testing devices

Easy-to-use gas charging valves with leak proof integrity are required for charging, discharging and pressure testing of hydraulic accumulators. HYDROTECHNIK fulfills these requirements with its gas charging valves.

The quality of a gas charging valve is essential for the long term use in plants with high safety regulations. The valves are easy to use with a safe and reliable connection.

The essential advantages:

- Very good leak proof integrity, leakage $<2 \times 10^{-5}$ mbar l s⁻¹ within allowed operating temperatures of -20°C to +135°C
- The application and construction is common with the MINIMESS®-coupling, which has been proven over many, many times
- Automatic opening of the gas charging valve when connecting a hose assembly
- Superior and safer manual connection without additional tools
- For different accumulator designs, suitable adapters are available
- Military authorised



Gas charging valves can be applied where hydraulic accumulators are used, for example in:

Mobile hydraulics

- Pressure energy source for power brake and steering boosters
- Spring element in the construction of vehicles and in stationary plants

Permanent hydraulic plant

- Maintaining the pressure in fastening devices, presses and pressing devices
- Additional sources of energy in stationary plant

MINIMESS®-gas charging valve 1615

Maximum working pressure 63 MPa

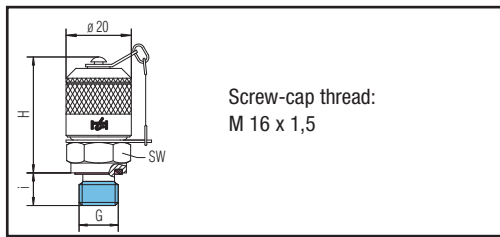

Compatible with the following media

Inert gases, nitrogen and compressed air. Resistant against antifreeze, oil, anti corrosion oil, grease and fuel.

Thread G		Type of sealing A	Torque in Nm	Technical data				Operating temperature range	Coupling material	Part-number with FKM sealings
				p max	H in mm	i in mm	SW in mm			
M 12 x 1,5	Form F		30	63 MPa	36,5	8,5	17	-20 °C bis +135 °C	1.4571	2402-01-13.50
M 14 x 1,5			40		36,5	10	19		1.4104	2402-01-14.00
ISO 228-G 1/4			40		36,5	10	19		1.4104	2402-01-18.00

Recorded with inspection certificate 3.1 B in accordance to DIN EN 10204, certificate 2.2. in accordance to DIN EN 10204

M 14 x 1,5	Form B	40	63 MPa	36,5	10	19	-33 °C bis +135 °C	1.4104	2402-01-49.70
------------	--------	----	--------	------	----	----	--------------------	--------	----------------------

Material

Body: 1.4104 (C4)
Pressure spring: 1.4310
Screw cap: brass (blackened)

Sealing

Internal primary and secondary sealing as well as integral seat seal and anti vibration O-ring (to prevent loosening of the metal cap) made of Viton.

Attention: Before using oxygen, please ensure you rinse and clean the gas charging valve.

Adapter incorporating gas charging valve 1615 made of stainless steel

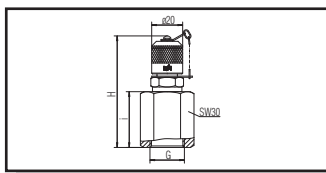

Thread of accumulator	Type of hydraulic accumulator	p max	Material	H in mm	I in mm	SW in mm	Part-number with FKM - sealing
7/8"-14 UNF	Bosch-bubble accumul.	63 MPa	1.4104	73	36	30	2446-16-30.00
M 28 x 1,5	Bosch-diaphragm accumul.			63	26	36	2446-18-30.00

Gas charging valve adapter 1615

To be directly screwed on the original valve of the accumulator

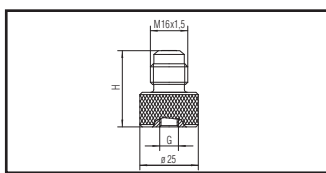

Thread of accumulator	Type of hydraulic accumulator	p max	Material	H in mm	Part-number with FKM - sealing
VG 8 DIN 7756	Langen	63 MPa	1.0718	32	5414-02-00.00
5/16"-32 UNEF	US			32	5414-02-10.00

Surface protection: galvanized and chromated. Further screw-in threads on request.

Accumulator charging and testing devices

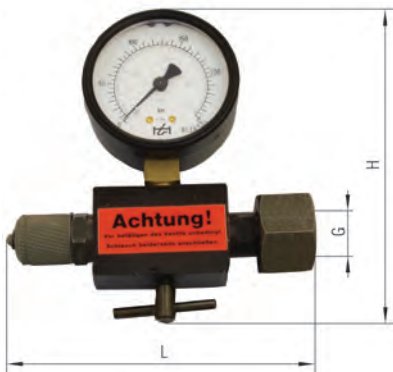

Pressure gauge display range	Measuring connection	Cylinder connection thread G	H in mm	L in mm	SW in mm	Part-number
0–400 bar	MINIMESS® 1615	W 24,32 x 1/14"	124	123	28	5114-01-00.10
0–250 bar	MINIMESS® 1620	W 24,32 x 1/14"	124	123	28	5114-21-03.00

- Charging of the hydraulic accumulator
- Testing and lowering the pressure within the hydraulic accumulator
- Pressure gauge Cl. 1,6 - Ø 63 mm

Complete measuring equipment kit on request.

Gas charging and testing device with pressure reducer valve



Secondary adjustment	Pressure gauge display range, secondary	Cylinder connection thread G	Connection secondary	SW in mm	Part-number
1,0–235 bar	0–250 bar	W 24,32 x 1/14"	MINIMESS® 1615	28	5401-02-00.00
1,0–235 bar	0–250 bar	W 21,8 x 1/14"	MINIMESS® 1615	28	5401-02-02.00

- Filling, adjusting and controlling gas pressure in hydraulic accumulators with nitrogen filling
- Pressure gauge Cl. 1,6 - Ø 63 mm
- Pressure gauge for primary pressure display 0 to 400 bar

Complete measuring equipment kit on request.

Gas charging and flushing device with pressure reducer valve for low pressure



Secondary adjustment	Pressure gauge display range, secondary	Cylinder connection thread G	Connection secondary	SW in mm	Part-number
0–1,3 bar	0–1,6 bar	W 24,32 x 1/14"	MINIMESS® 1615	28	5401-07-00.00
Complete measuring equipment with transport case and high pressure hose					5401-07-00.10

- Pre-adjustment of the flushing- and charging pressure
- Flushing and charging of nitrogen systems
- Pressure gauge Cl. 1,6 - Ø 63 mm
- Pressure gauge for primary pressure display 0 to 250 bar

Compatibility table

- Sealing material: Viton
- Free-cutting steel 1.0718 (9SMnPb28K), gradually change over to chrome (VI)-free surface treatment
- Corrosion-resistant stainless steel 1.4104 (X 12CrMoS 17)
- Acid proof stainless steel 1.4571 (X 10CrNiMoTi 1810) antimagnetic
- Hoses: polyamide 11

All statements are not binding and are only for your information

Flow rate media	Sealing	Fittings / Material			Hoses			
		1.0718	1.4104	1.4571	20 °C	40 °C	60 °C	90 °C
Acetone	3 *)	1	2	1	1/5	1/6	2	3
Ethyl alcohol, pure	1/2	1	1	1	1/6	2	3	
Ammonia, concentrated	3 *)	1	1	1	1	1	1	1
Ammonia, liquid	3 *)	1	1	1	1	1		
Formic acid	3 *)	3	2	1	3	3	3	
Gasoline, pure	1	1	1	1	1	1	1/6	
Benzene	1/2	1	1	1	1	1/6	2	2
Brake fluid	3 *)	1	1	1	1	1	1	2
Butane	1	2	1	1	1	1	1	
Cyclohexane	1	1	1	1	1	1	2	
Diesel motor fuel	1	1	1	1	1	1	1	1
Freon 12	1/2	1	1	1	1	1	1	1
Glycerin, pure	1/2	1	1	1	1	1	2	3
Glycols	1/2	1	1	1	1	1	2	3
Heating oil	1	1	1	1	1	1	1	1
Hydraulic fluid (mineral oil base)	1	1	1	1	1	1	1	1
Kerosene	1	1	1	1	1	1	1/6	
Carbon dioxide	1	3	1	1	1/4	1/4	1/4	
Methane	1	2	1	1	1/4	1/4	1/4	
Methyl alcohol, pure	3 *)	1	1	1	1/6	2	3	
Mineral oils	1	1	1	1	1	1	1	1
Petroleum	1	1	1	1	1	1	1/6	
Polyalkyleneglycol (HEPG)	2 (<100 °C)	2	1	1	1	1	2/4	3/4
Propane	1	2	1	1	1/4	1/4	1/4	
Oxygen	1	3	1	1	1/4	1/4	2/4	3/4
Lubricating oils and grease	1	1	1	1	1	1	1	1
Soap solution	1	3	1	1	1	1	1	1
Nitrogen	1	1	1	1	1/4	1/4	1/4	
Synthetic esters (HEES)	2 (<100 °C)	1	1	1	1	1	2/4	3/4
Essence of turpentine	1	2	1	1	1	1	1/6	
Tetra chloromethane	1	2	1	1	1	3		
Toluene	1/2	2	1	1	1	1/6	2	2
Trichloroethylene	1/2	1	1	1	2	3		
Triglycerides (HETG)	2 (<80 °C)	1	1	1	1	1	2/4	3/4
Water	1	3	1	1	1	1	1	1
Sea water	1	3	3	2	1	1	1	1

*) Application of suitable sealing materials on request.

Explanations:

- 1 = good, absolute resistance without modifications
- 2 = limited, resistance depends on using time and operating conditions
- 3 = not recommended - material is affected and the mechanical characteristics are decreased
- 4 = slight diffusion when using gases; can only be used as a test- and filling hose. For permanent use, we recommend our measuring tubes made of stainless steel
- 5 = the transparent material can change the colour
- 6 = slight swelling, but no modifications of the mechanical characteristics

If your medium of application is not mentioned, please get in contact with us.

Conversion table of the pressure measuring units

Units	PA N/m ²	MPa MN/m ²	bar	mbar	mWS	mmWS	mmHg (Torr)	psi	kp/cm ² (at)
1 Pa = 1N/m²	1	10 ⁻⁶	10 ⁻⁵	10 ⁻²	1,02 x 10 ⁻⁴	1,02 x 10 ⁻¹	7,5 x 10 ⁻³	1,45 x 10 ⁻⁴	1,02 x 10 ⁻⁵
1 MPa = 1MN/m²	10 ⁶	1	10	10 ⁴	102	1,02 x 10 ⁵	7500	145	10,2
1 bar	10 ⁵	10 ⁻¹	1	10 ³	10,2	1,02 x 10 ⁴	750	14,5	1,02
1 mbar	10 ²	10 ⁻⁴	10 ⁻³	1	1,02 x 10 ⁻²	10,2	7,5 x 10 ⁻¹	1,45 x 10 ⁻²	1,02 x 10 ⁻³
1 mWS	9,81 x 10 ³	9,81 x 10 ⁻³	9,81 x 10 ⁻²	9,81 x 10 ¹	1	10 ³	7,36 x 10 ¹	1,42	10 ⁻¹
1 mmWS	9,81	9,81 x 10 ⁻⁶	9,81 x 10 ⁻⁵	9,81 x 10 ⁻²	10 ⁻³	1	7,36 x 10 ⁻²	1,42 x 10 ⁻³	10 ⁻⁴
1 mmHg (Torr)	1,33 x 10 ²	1,33 x 10 ⁻⁴	1,33 x 10 ⁻³	1,33	1,36 x 10 ⁻²	1,36 x 10 ¹	1	1,93 x 10 ⁻²	1,36 x 10 ⁻³
1 psi	6,89 x 10 ³	6,89 x 10 ⁻³	6,89 x 10 ⁻²	6,89 x 10 ¹	7,03 x 10 ⁻¹	7,03 x 10 ²	5,17 x 10 ¹	1	7,03 x 10 ⁻²
1 kp/cm² (at)	9,81 x 10 ⁴	9,81 x 10 ⁻²	9,81 x 10 ⁻¹	9,81 x 10 ²	10	10 ⁴	7,36 x 10 ²	1,42 x 10 ¹	1

Definition of the units:

at	Technical atmosphere	bar	bar
kp/cm²	Kilopond per square centimetre	mbar	Milibar
Pa	Pascal	mWS	Meter water pillar
MPa	Mega-Pascal	mmWS	Millimetre water pillar
N/m²	Newton per square metre	mmHg	Millimetre mercury pillar at = 0°C
MN/m²	Mega-Newton per square metre	psi	English pound per square inch

HYDROTECHNIK GmbH
Holzheimer Straße 94–96 | 65549 Limburg
Tel. 0 64 31.40 04-0 | Fax 0 64 31.4 53 08
www.hydrotechnik.com | info@hydrotechnik.com

