

LMP 210-211

Maximum pressure up to 60 bar - Flow rate up to 330 l/min



The correct filter sizing have to be based on the variable pressure drop depending by the application. For example, for the return filter the pressure drop have to be in the range 0.4 - 0.6 bar.

The pressure drop calculation is performed by adding together the value of the housing with the value of the filter element. The pressure drop in the housing is proportional to the fluid density (kg/dm³); all the graphs in the catalogue are referred to mineral oil with density of 0.86 kg/dm³.

The filter element pressure drop is proportional to its viscosity (mm²/s), the corrective factor Y is related to an oil viscosity different than 30 mm²/s.

Sizing data for single cartridge, head at top

Δp_c = Filter housing pressure drop [bar]

Δp_e = Filter element pressure drop [bar]

Y = Multiplication factor Y (see correspondent table), depending on the filter element size, on the filter element length and on the filter media

Q = flow rate (l/min)

V1 reference viscosity = 30 mm²/s (cSt)

V2 = operating viscosity in mm²/s (cSt)

$\Delta p_e = Y : 1000 \times Q \times (V2/V1)$

$\Delta p_{Tot.} = \Delta p_c + \Delta p_e$

Calculation examples with HLP Mineral oil Variation in viscosity

Application data:

Top tank return filter

Filter with in-line connections

Pressure Pmax = 10 bar

Flow rate Q = 120 l/min

Viscosity V2 = 46 mm²/s (cSt)

Oil viscosity = 0.86 kg/dm³

Required filtration efficiency = 25 µm with absolute filtration

With bypass valve and 1 1/4" inlet connection

From the working pressure and the flow rate we understand it should be possible using the following top tank return filter series: MPT, MPH and FRI. Let's proceed with MPT series.

The size 20 doesn't achieve the required flow rate, therefore we have to consider the size 100. The final version of size 100 (101, 104, 110, 120 and 114) will be then defined in function of the mounting characteristics.

$\Delta p_c = 0.03 \text{ bar}$ (★ see graphic below, considering size 100 with the max available length to get the lowest pressure drop)

$\Delta p_e = (2.0 : 1000) \times 120 \times (46/30) = 0.37 \text{ bar}$

$\Delta p_{Tot.} = 0.03 + 0.37 = 0.4 \text{ bar}$

The selection is correct because the total pressure drop value is inside the admissible range for top tank return filters. It is of course possible trying to find a different solution, according to the mounting position or to other commercial need, repeating the previous steps while using a different series or length.

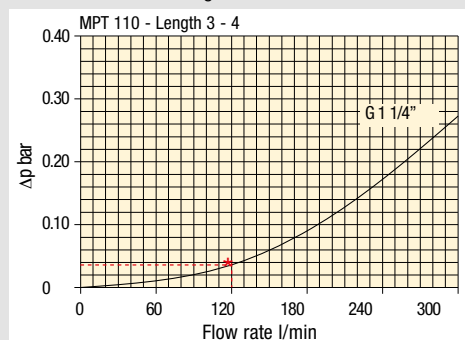

Filter housings Δp pressure drop.

The curves are plotted using mineral oil with density of 0.86 kg/dm³ in compliance with ISO 3968. Δp varies proportionally with density.

Corrective factor Y, to be used for the filter element pressure drop calculation. The values depend to the filter size and length and to the filter media.

Reference viscosity 30 mm²/s

Return filters

Filter element Type	Absolute filtration H Series					Nominal filtration N Series			
	A03	A06	A10	A16	A25	P10	P25	M25 M60 M90	
MF 020	1	74.00	50.08	20.00	16.00	9.00	6.43	5.51	4.40
	2	29.20	24.12	8.00	7.22	5.00	3.33	2.85	2.00
	3	22.00	19.00	6.56	5.33	4.33	1.68	1.44	1.30
MF 030 MFX 030	1	74.00	50.08	20.00	16.00	9.00	6.43	5.51	3.40
MF 100 MFX 100	1	28.20	24.40	8.67	8.17	6.88	4.62	3.96	1.25
	2	17.33	12.50	6.86	5.70	4.00	3.05	2.47	1.10
	3	10.25	9.00	3.65	3.33	2.50	1.63	1.32	0.96
	4	6.10	5.40	2.30	2.20	2.00	1.19	0.96	0.82
MF 180 MFX 180	1	3.67	3.05	1.64	1.56	1.24	1.18	1.06	0.26
	2	1.69	1.37	0.68	0.54	0.51	0.43	0.39	0.12
MF 190 MFX 190	2	1.69	1.37	0.60	0.49	0.44	0.35	0.31	0.11
MF 400 MFX 400	1	3.20	2.75	1.39	1.33	1.06	0.96	0.87	0.22
	2	2.00	1.87	0.88	0.85	0.55	0.49	0.45	0.13
	3	1.90	1.60	0.63	0.51	0.49	0.39	0.35	0.11
MF 750 MFX 750	1	1.08	0.84	0.49	0.36	0.26	0.21	0.19	0.06
CU 025		78.00	48.00	28.00	24.00	9.33	9.33	8.51	1.25
CU 040		25.88	20.88	10.44	10.00	3.78	3.78	3.30	1.25
CU 100		15.20	14.53	5.14	4.95	2.00	2.00	0.17	1.10
CU 250		3.25	2.55	1.55	1.35	0.71	0.71	0.59	0.25
CU 630		1.96	1.68	0.85	0.72	0.42	0.42	0.36	0.09
CU 850		1.06	0.84	0.42	0.33	0.17	0.17	0.13	0.04
MR 100	1	19.00	17.00	6.90	6.30	4.60	2.94	2.52	1.60
	2	11.70	10.80	4.40	4.30	3.00	2.94	2.52	1.37
	3	7.80	6.87	3.70	3.10	2.70	2.14	1.84	1.34
	4	5.50	4.97	2.60	2.40	2.18	1.72	1.47	1.34
	5	4.20	3.84	2.36	2.15	1.90	1.60	1.37	1.34
MR 250	1	5.35	4.85	2.32	1.92	1.50	1.38	1.20	0.15
	2	4.00	3.28	1.44	1.10	1.07	0.96	0.83	0.13
	3	2.60	2.20	1.08	1.00	0.86	0.77	0.64	0.12
	4	1.84	1.56	0.68	0.56	0.44	0.37	0.23	0.11
MR 630	1	3.10	2.48	1.32	1.14	0.92	0.83	0.73	0.09
	2	2.06	1.92	0.82	0.76	0.38	0.33	0.27	0.08
	3	1.48	1.30	0.60	0.56	0.26	0.22	0.17	0.08
	4	1.30	1.20	0.48	0.40	0.25	0.21	0.16	0.08
	5	0.74	0.65	0.30	0.28	0.13	0.10	0.08	0.04
MR 850	1	0.60	0.43	0.34	0.25	0.13	0.12	0.09	0.03
	2	0.37	0.26	0.23	0.21	0.11	0.08	0.07	0.03
	3	0.27	0.18	0.17	0.17	0.05	0.04	0.04	0.02
	4	0.23	0.16	0.13	0.12	0.04	0.03	0.03	0.02

Corrective factor Y, to be used for the filter element pressure drop calculation.
The values depend to the filter size and lenght and to the filter media.

Reference viscosity 30 mm²/s

Suction filters

Filter element	Nominal filtration N Series	
	P10	P25
SF 250	65	21

Return / Suction filters

Filter element	Absolute filtration			
	A10	A16	A25	
RSX 116	1	5.12	4.33	3.85
	2	2.22	1.87	1.22
RSX 165	1	2.06	1.75	1.46
	2	1.24	1.05	0.96
	3	0.94	0.86	0.61

Low & Medium pressure filters

Filter element	Type	Absolute filtration N-W Series					Nominal filtration N Series		
		A03	A06	A10	A16	A25	P10	P25	M25
CU 110	1	16.25	15.16	8.75	8.14	5.87	2.86	2.65	0.14
	2	12.62	10.44	6.11	6.02	4.15	1.60	1.49	0.12
	3	8.57	7.95	5.07	4.07	2.40	1.24	1.15	0.11
	4	5.76	4.05	2.80	2.36	1.14	0.91	0.85	0.05
CU 210	1	5.30	4.80	2.00	1.66	1.32	0.56	0.43	0.12
	2	3.44	2.95	1.24	1.09	0.70	0.42	0.35	0.09
	3	2.40	1.70	0.94	0.84	0.54	0.33	0.23	0.05
DN	016	7.95	7.20	3.00	2.49	1.98	0.84	0.65	0.18
	025	5.00	4.53	1.89	1.57	1.25	0.53	0.41	0.11
	040	3.13	2.66	1.12	0.98	0.63	0.38	0.32	0.08
CU 400	2	3.13	2.55	1.46	1.22	0.78	0.75	0.64	0.19
	3	2.15	1.70	0.94	0.78	0.50	0.40	0.34	0.10
	4	1.60	1.28	0.71	0.61	0.40	0.34	0.27	0.08
	5	1.00	0.83	0.47	0.34	0.20	0.24	0.19	0.06
	6	0.82	0.58	0.30	0.27	0.17	0.22	0.18	0.05
	CU 900	1	0.86	0.63	0.32	0.30	0.21	-	-
CU 950	2	1.03	0.80	0.59	0.40	0.26	-	-	0.05
	3	0.44	0.40	0.27	0.18	0.15	-	-	0.02
MR 630	7	0.88	0.78	0.36	0.34	0.16	0.12	0.96	0.47

FILTER SIZING Corrective factor

Corrective factor **Y**, to be used for the filter element pressure drop calculation.
The values depend to the filter size and lenght and to the filter media.

Reference viscosity 30 mm²/s

High pressure filters

Filter element	Absolute filtration N - R Series					Nominal filtration N Series	
	Type	A03	A06	A10	A16		A25
HP 011	1	332.71	250.07	184.32	152.36	128.36	-
	2	220.28	165.56	74.08	59.13	37.05	-
	3	123.24	92.68	41.48	33.08	20.72	-
	4	77.76	58.52	28.37	22.67	16.17	-
HP 039	1	70.66	53.20	25.77	20.57	14.67	4.90
	2	36.57	32.28	18.00	13.38	8.00	2.90
	3	26.57	23.27	12.46	8.80	5.58	2.20
HP 050	1	31.75	30.30	13.16	12.3	7.29	1.60
	2	24.25	21.26	11.70	9.09	4.90	1.40
	3	17.37	16.25	8.90	7.18	3.63	1.25
	4	12.12	10.75	6.10	5.75	3.08	1.07
	5	7.00	6.56	3.60	3.10	2.25	0.80
HP 065	1	58.50	43.46	23.16	19.66	10.71	1.28
	2	42.60	25.64	16.22	13.88	7.32	1.11
	3	20.50	15.88	8.18	6.81	3.91	0.58
HP 135	1	20.33	18.80	9.71	8.66	4.78	2.78
	2	11.14	10.16	6.60	6.38	2.22	1.11
	3	6.48	6.33	3.38	3.16	2.14	1.01
HP 320	1	10.88	9.73	5.02	3.73	2.54	1.04
	2	4.40	3.83	1.75	1.48	0.88	0.71
	3	2.75	2.11	1.05	0.87	0.77	0.61
	4	2.12	1.77	0.98	0.78	0.55	0.47
HP 500	1	4.44	3.67	2.30	2.10	1.65	0.15
	2	3.37	2.77	1.78	1.68	1.24	0.10
	3	2.22	1.98	1.11	1.09	0.75	0.08
	4	1.81	1.33	0.93	0.86	0.68	0.05
	5	1.33	1.15	0.77	0.68	0.48	0.04

Filter element	Absolute filtration N Series					Nominal filtration N Series	
	Type	A03	A06	A10	A16		A25
HP 320	1	3.65	2.95	2.80	1.80	0.90	0.38
	2	2.03	1.73	1.61	1.35	0.85	0.36
	3	1.84	1.42	1.32	1.22	0.80	0.35

Stainless steel high pressure filters

Filter element	Absolute filtration N Series					
	Type	A03	A06	A10	A16	A25
HP 011	1	332.71	250.07	184.32	152.36	128.36
	2	220.28	165.56	74.08	59.13	37.05
	3	123.24	92.68	41.48	33.08	20.72
	4	77.76	58.52	28.37	22.67	16.17
HP 039	2	70.66	53.20	25.77	20.57	14.67
	3	36.57	32.28	18.00	13.38	8.00
	4	26.57	23.27	12.46	0.88	5.58
	1	31.75	30.30	13.16	12.3	7.29
HP 050	2	24.25	21.26	11.70	9.09	4.90
	3	17.37	16.25	8.90	7.18	3.63
	4	12.12	10.75	6.10	5.75	3.08
	5	7.00	6.56	3.60	3.10	2.25
	1	20.33	18.80	9.71	8.66	4.78
HP 135	2	11.14	10.16	6.60	6.38	2.22
	3	6.48	6.33	3.38	3.16	2.14

Filter element	Absolute filtration H - U Series					
	Type	A03	A06	A10	A16	A25
HP 011	1	424.58	319.74	235.17	194.44	163.78
	2	281.06	211.25	94.53	75.45	47.26
	3	130.14	97.50	43.63	34.82	21.81
	4	109.39	82.25	36.79	29.37	18.40
HP 039	2	70.66	53.20	25.77	20.57	14.67
	3	36.57	32.28	18.00	13.38	8.00
	4	26.57	23.27	12.46	8.80	5.58
	1	47.33	34.25	21.50	20.50	14.71
HP 050	2	29.10	25.95	14.04	10.90	5.88
	3	20.85	19.50	10.68	8.61	4.36
	4	14.55	12.90	7.32	6.90	3.69
	5	9.86	9.34	6.40	4.80	2.50
	1	29.16	25.33	13.00	12.47	5.92
HP 135	2	14.28	11.04	7.86	7.60	4.44
	3	8.96	7.46	4.89	4.16	3.07

Step 1 Select "FILTERS"



Step 2 Choose filter group (Return Filter, Pressure Filter, etc.)



Step 3 Choose filter type (MPF, MPT, etc.) in function of the max working pressure and the max flow rate



Step 4 Push "PROCEED"



Step 5

Insert all application data to calculate the filter size following the sequence:

- working pressure
- working flow rate
- working pressure drop
- working temperature
- fluid material and fluid type
- filtration media
- connection type

Step 6

Push "CALCULATE" to have result; in case of any mistake, the system will advice which parameter is out of range to allow to modify/adjust the selection

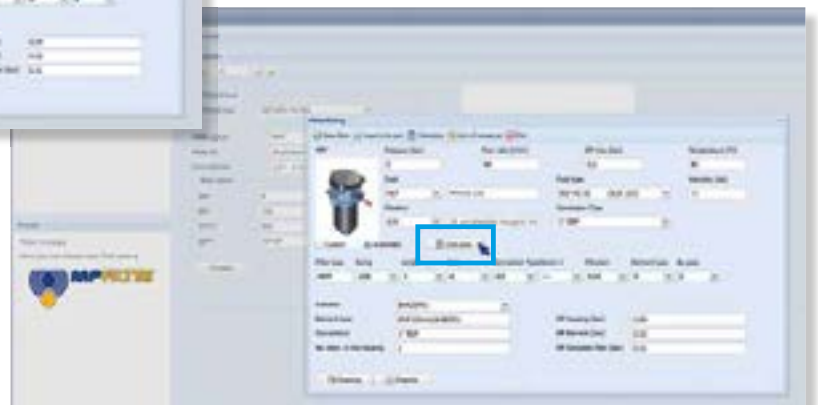

Step 7

Download PDF Datasheet "Report.aspx" pushing the button "Drawing"

LMP 210-211

Maximum pressure up to 60 bar - Flow rate up to 330 l/min



LMP210-211 GENERAL INFORMATION

Technical data

Low & Medium Pressure filters Maximum pressure up to 60 bar - Flow rate up to 330 l/min

Filter housing materials

- Head: Aluminium
- Bowl: Cataphoretic Painted Steel
- Bypass valve: AISI 304 - Nylon

Seals

- Standard NBR series A
- Optional FPM series V

Pressure

- Working pressure: 6 MPa (60 bar)
- Test pressure: 9 MPa (90 bar)
- Burst pressure: 21 MPa (210 bar)
- Pulse pressure fatigue test: 1 000 000 cycles with pressure from 0 to 6 MPa (60 bar)

Temperature

From -25 °C to +110 °C

Connections

Inlet/Outlet In-Line

Bypass valve

- Opening pressure 3.5 bar \pm 10%
- Other opening pressures on request.

Note

LMP 210 - 211 filters are provided for vertical mounting

Δp element type

- Microfibre filter elements - series N: 20 bar
- Fluid flow through the filter element from OUT to IN.

Weights [kg] and volumes [dm³]

	Weights [kg]			Volumes [dm ³]				
	Length	1	2	3	Length	1	2	3
LMP 210 - 211		3.10	4.80	6.40		1.60	2.10	2.80

Hydraulic symbols

LMP 210-400-900-950
execution **S**

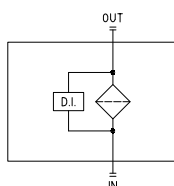

LMP 210-400-900-950
execution **B**

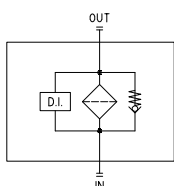

GENERAL INFORMATION LMP210-211

The curves are plotted using mineral oil with density of 0.86 kg/dm³ in compliance with ISO 3968.

Δp varies proportionally with density.

Pressure drop

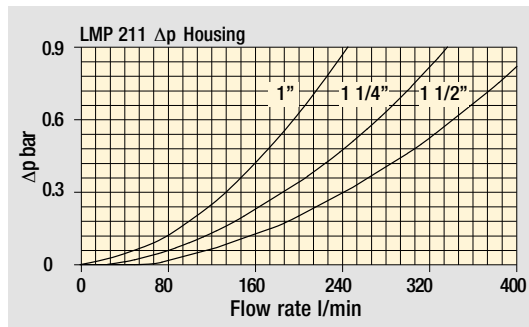
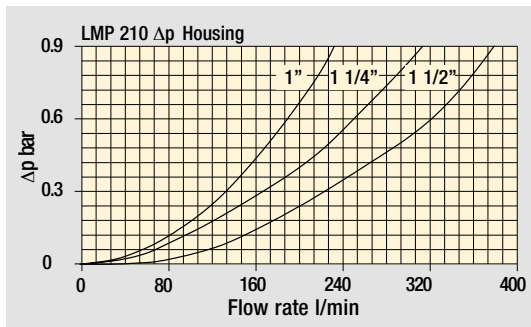

Filter housings Δp pressure drop

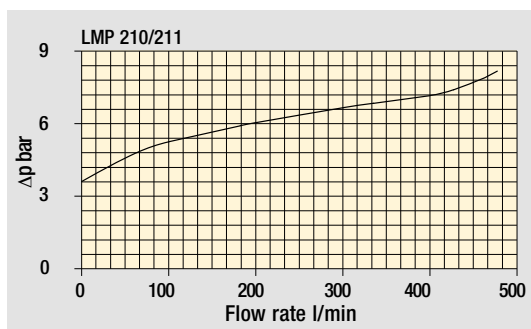

Bypass valve pressure drop

LMP210

Designation & Ordering code

COMPLETE FILTER

Series and size LMP210	Configuration example: LMP210 3 B A F1 A10 N P01									
Length 1 2 3										
Bypass valve S Without bypass B 3.5 bar										
Seals and treatments	Filtration rating									
A NBR	Axx	Mxx	Pxx							
V FPM	•	•	•							
W NBR compatible with fluids HFA-HFB-HFC	•	•								
Connections										
F1 1" SAE 3000 psi/M										
F2 1 1/4" SAE 3000 psi/M										
F3 1 1/2" SAE 3000 psi/M										
F4 1" SAE 3000 psi/UNC										
F5 1 1/4" SAE 3000 psi/UNC										
F6 1 1/2" SAE 3000 psi/UNC										
Filtration rating (filter media)										
A03 Inorganic microfiber 3 µm										
A06 Inorganic microfiber 6 µm										
A10 Inorganic microfiber 10 µm										
A16 Inorganic microfiber 16 µm										
A25 Inorganic microfiber 25 µm										
M25 Wire mesh 25 µm										
M60 Wire mesh 60 µm										
M90 Wire mesh 90 µm										
P10 Resin impregnated paper 10 µm										
P25 Resin impregnated paper 25 µm										
				Element Δp N 20 bar			Execution P01 MP Filtri standard Pxx Customized			

FILTER ELEMENT

Element series and size CU210	Configuration example: CU210 3 A10 A N P01							
Element length 1 2 3								
Filtration rating (filter media)								
A03 Inorganic microfiber 3 µm								
A06 Inorganic microfiber 6 µm								
A10 Inorganic microfiber 10 µm								
A16 Inorganic microfiber 16 µm								
A25 Inorganic microfiber 25 µm								
M25 Wire mesh 25 µm								
M60 Wire mesh 60 µm								
M90 Wire mesh 90 µm								
P10 Resin impregnated paper 10 µm								
P25 Resin impregnated paper 25 µm								
Seals	Filtration rating							
A NBR	Axx	Mxx	Pxx					
V FPM	•	•	•					
W NBR compatible with fluids HFA-HFB-HFC	•	•						
				Element Δp N 20 bar		Execution P01 MP Filtri standard Pxx Customized		

ACCESSORIES

Differential indicators	page		page
DEA Electrical differential indicator	419	DTA Electronic differential indicator	422
DEM Electrical differential indicator	419-420	DVA Visual differential indicator	422
DLA Electrical / visual differential indicator	420-421	DVM Visual differential indicator	422
DLE Electrical / visual differential indicator	421		
Additional features	page		
T2 Plug	423		

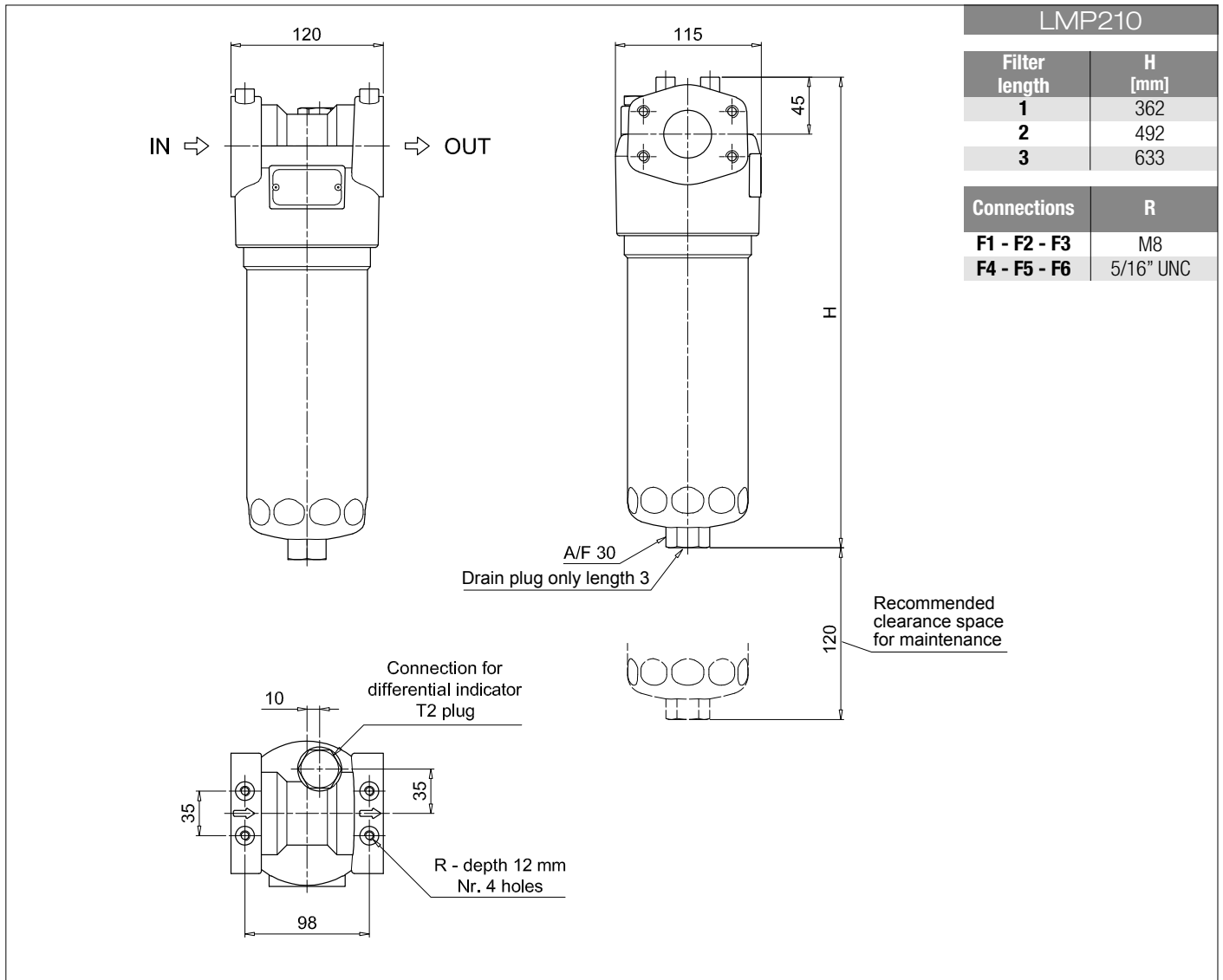

LMP211

Designation & Ordering code

COMPLETE FILTER

Series and size	Configuration example: LMP211 3 B A D 6 A10 N P01									
LMP211										
Length	1 2 3									
Bypass valve	S Without bypass B 3.5 bar									
Seals and treatments	Filtration rating									
A NBR	Axx	Mxx	Pxx							
V FPM	•	•	•							
W NBR compatible with fluids HFA-HFB-HFC	•	•								
Connections										
A G1"										
B G1 1/4"										
C G1 1/2"										
D 1" NPT										
E 1 1/4" NPT										
F 1 1/2" NPT										
G SAE 16 - 1 5/16" - 12 UN										
H SAE 20 - 1 5/8" - 12 UN										
I SAE 24 - 1 7/8" - 12 UN										
Connection for differential indicator	6 With plugged connection									
Filtration rating (filter media)										
A03 Inorganic microfiber 3 µm	M25 Wire mesh 25 µm									
A06 Inorganic microfiber 6 µm	M60 Wire mesh 60 µm									
A10 Inorganic microfiber 10 µm	M90 Wire mesh 90 µm									
A16 Inorganic microfiber 16 µm	P10 Resin impregnated paper 10 µm									
A25 Inorganic microfiber 25 µm	P25 Resin impregnated paper 25 µm									
			Element Δp			Execution				
			N 20 bar			P01 MP Filtri standard				
						Pxx Customized				

FILTER ELEMENT

Element series and size	Configuration example: CU210 3 A10 A N P01						
CU210							
Element length	1 2 3						
Filtration rating (filter media)							
A03 Inorganic microfiber 3 µm	M25 Wire mesh 25 µm						
A06 Inorganic microfiber 6 µm	M60 Wire mesh 60 µm						
A10 Inorganic microfiber 10 µm	M90 Wire mesh 90 µm						
A16 Inorganic microfiber 16 µm	P10 Resin impregnated paper 10 µm						
A25 Inorganic microfiber 25 µm	P25 Resin impregnated paper 25 µm						
Seals	Filtration rating						
A NBR	Axx	Mxx	Pxx				
V FPM	•	•	•				
W NBR compatible with fluids HFA-HFB-HFC	•	•					
			Element Δp		Execution		
			N 20 bar		P01 MP Filtri standard		
					Pxx Customized		

ACCESSORIES

Differential indicators	page		page
DEA Electrical differential indicator	419	DTA Electronic differential indicator	422
DEM Electrical differential indicator	419-420	DVA Visual differential indicator	422
DLA Electrical / visual differential indicator	420-421	DVM Visual differential indicator	422
DLE Electrical / visual differential indicator	421		
Additional features	page		
T2 Plug	423		

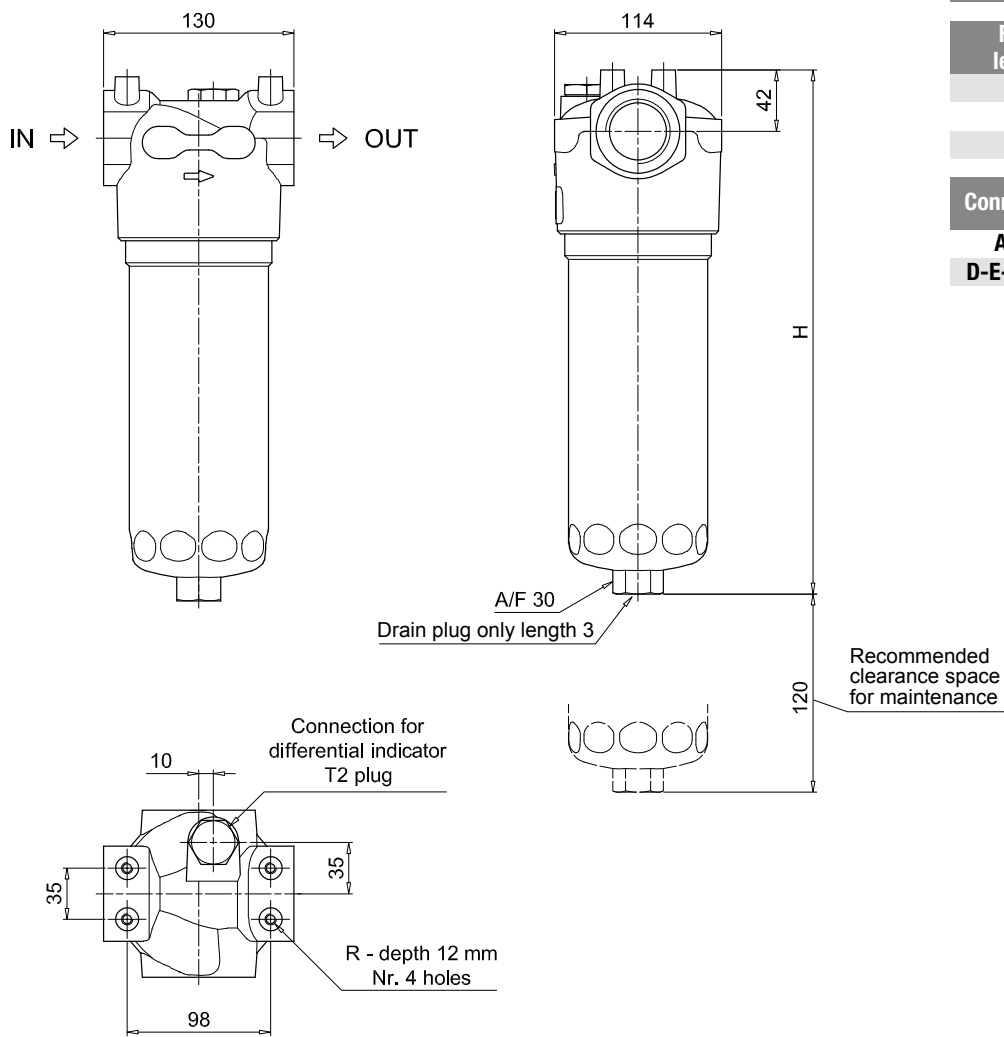

LMP211	
Filter length	H [mm]
1	358
2	488
3	629
Connections	R
A-B-C	M8
D-E-F-G-H-I	5/16" UNC

LMP210-211 SPARE PARTS

Order number for spare parts

LMP 210

LMP 211

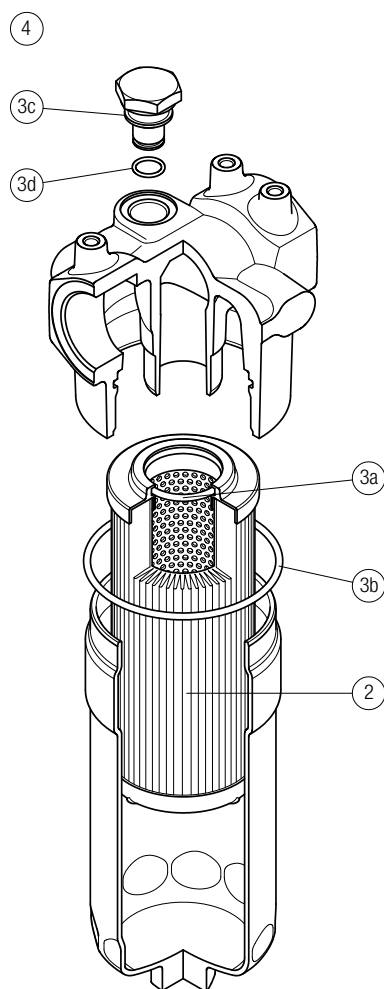
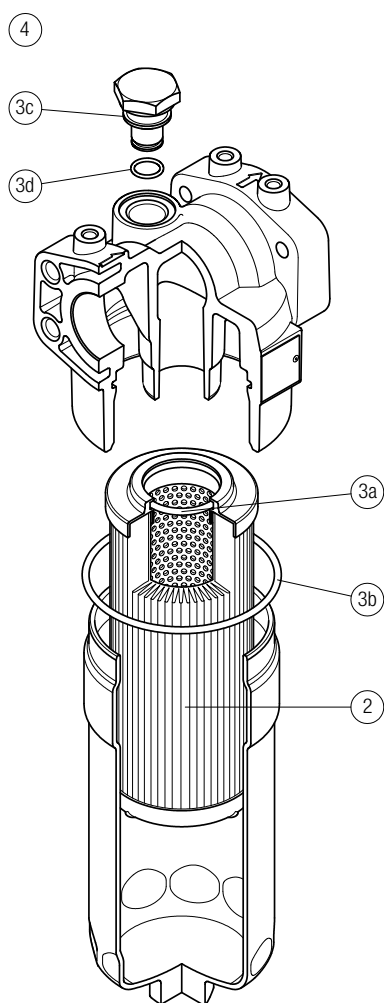

Item:	Q.ty: 1 pc. 2	Q.ty: 1 pc. 3 (3a ÷ 3d)		Q.ty: 1 pc. 4	
Filter series	Filter element	Seal Kit code number		Indicator connection plug	
		NBR	FPM	NBR	FPM
LMP 210 - 211	See order table	02050435	02050436	T2H	T2V