

LMD 400-401 & 431 series

Maximum pressure up to 16 bar - Flow rate up to 590 l/min



The correct filter sizing have to be based on the variable pressure drop depending by the application. For example, for the return filter the pressure drop have to be in the range 0.4 - 0.6 bar.

The pressure drop calculation is performed by adding together the value of the housing with the value of the filter element. The pressure drop in the housing is proportional to the fluid density (kg/dm³); all the graphs in the catalogue are referred to mineral oil with density of 0.86 kg/dm³.

The filter element pressure drop is proportional to its viscosity (mm²/s), the corrective factor Y is related to an oil viscosity different than 30 mm²/s.

Sizing data for single cartridge, head at top

Δp_c = Filter housing pressure drop [bar]

Δp_e = Filter element pressure drop [bar]

Y = Multiplication factor Y (see correspondent table), depending on the filter element size, on the filter element lenght and on the filter media

Q = flow rate (l/min)

V1 reference viscosity = 30 mm²/s (cSt)

V2 = operating viscosity in mm²/s (cSt)

$\Delta p_e = Y : 1000 \times Q \times (V2/V1)$

$\Delta p_{Tot.} = \Delta p_c + \Delta p_e$

Calculation examples with HLP Mineral oil Variation in viscosity

Application data:

Top tank return filter

Filter with in-line connections

Pressure Pmax = 10 bar

Flow rate Q = 120 l/min

Viscosity V2 = 46 mm²/s (cSt)

Oil viscosity = 0.86 kg/dm³

Required filtration efficiency = 25 µm with absolute filtration

With bypass valve and 1 1/4" inlet connection

From the working pressure and the flow rate we understand it should be possible using the following top tank return filter series: MPT, MPH and FRI. Let's proceed with MPT series.

The size 20 doesn't achieve the required flow rate, therefore we have to consider the size 100. The final version of size 100 (101, 104, 110, 120 and 114) will be then defined in function of the mounting characteristics.

$\Delta p_c = 0.03 \text{ bar}$ (★ see graphic below, considering size 100 with the max available lenght to get the lowest pressure drop)

$\Delta p_e = (2.0 : 1000) \times 120 \times (46/30) = 0.37 \text{ bar}$

$\Delta p_{Tot.} = 0.03 + 0.37 = 0.4 \text{ bar}$

The selection is correct because the total pressure drop value is inside the admissible range for top tank return filters. It is of course possible trying to find a different solution, according to the mounting position or to other commercial need, repeating the previous steps while using a different series or lenght.



Filter housings Δp pressure drop.

The curves are plotted using mineral oil with density of 0.86 kg/dm³ in compliance with ISO 3968. Δp varies proportionally with density.

Corrective factor Y, to be used for the filter element pressure drop calculation. The values depend to the filter size and lenght and to the filter media.

Reference viscosity 30 mm²/s

Return filters

Filter element	Absolute filtration H Series					Nominal filtration N Series			
	Type	A03	A06	A10	A16	A25	P10	P25	M25 M60 M90
MF 020	1	74.00	50.08	20.00	16.00	9.00	6.43	5.51	4.40
	2	29.20	24.12	8.00	7.22	5.00	3.33	2.85	2.00
	3	22.00	19.00	6.56	5.33	4.33	1.68	1.44	1.30
MF 030 MFX 030	1	74.00	50.08	20.00	16.00	9.00	6.43	5.51	3.40
MF 100 MFX 100	1	28.20	24.40	8.67	8.17	6.88	4.62	3.96	1.25
	2	17.33	12.50	6.86	5.70	4.00	3.05	2.47	1.10
	3	10.25	9.00	3.65	3.33	2.50	1.63	1.32	0.96
	4	6.10	5.40	2.30	2.20	2.00	1.19	0.96	0.82
MF 180 MFX 180	1	3.67	3.05	1.64	1.56	1.24	1.18	1.06	0.26
	2	1.69	1.37	0.68	0.54	0.51	0.43	0.39	0.12
MF 190 MFX 190	2	1.69	1.37	0.60	0.49	0.44	0.35	0.31	0.11
MF 400 MFX 400	1	3.20	2.75	1.39	1.33	1.06	0.96	0.87	0.22
	2	2.00	1.87	0.88	0.85	0.55	0.49	0.45	0.13
	3	1.90	1.60	0.63	0.51	0.49	0.39	0.35	0.11
MF 750 MFX 750	1	1.08	0.84	0.49	0.36	0.26	0.21	0.19	0.06
CU 025		78.00	48.00	28.00	24.00	9.33	9.33	8.51	1.25
CU 040		25.88	20.88	10.44	10.00	3.78	3.78	3.30	1.25
CU 100		15.20	14.53	5.14	4.95	2.00	2.00	0.17	1.10
CU 250		3.25	2.55	1.55	1.35	0.71	0.71	0.59	0.25
CU 630		1.96	1.68	0.85	0.72	0.42	0.42	0.36	0.09
CU 850		1.06	0.84	0.42	0.33	0.17	0.17	0.13	0.04
MR 100	1	19.00	17.00	6.90	6.30	4.60	2.94	2.52	1.60
	2	11.70	10.80	4.40	4.30	3.00	2.94	2.52	1.37
	3	7.80	6.87	3.70	3.10	2.70	2.14	1.84	1.34
	4	5.50	4.97	2.60	2.40	2.18	1.72	1.47	1.34
	5	4.20	3.84	2.36	2.15	1.90	1.60	1.37	1.34
MR 250	1	5.35	4.85	2.32	1.92	1.50	1.38	1.20	0.15
	2	4.00	3.28	1.44	1.10	1.07	0.96	0.83	0.13
	3	2.60	2.20	1.08	1.00	0.86	0.77	0.64	0.12
	4	1.84	1.56	0.68	0.56	0.44	0.37	0.23	0.11
MR 630	1	3.10	2.48	1.32	1.14	0.92	0.83	0.73	0.09
	2	2.06	1.92	0.82	0.76	0.38	0.33	0.27	0.08
	3	1.48	1.30	0.60	0.56	0.26	0.22	0.17	0.08
	4	1.30	1.20	0.48	0.40	0.25	0.21	0.16	0.08
	5	0.74	0.65	0.30	0.28	0.13	0.10	0.08	0.04
MR 850	1	0.60	0.43	0.34	0.25	0.13	0.12	0.09	0.03
	2	0.37	0.26	0.23	0.21	0.11	0.08	0.07	0.03
	3	0.27	0.18	0.17	0.17	0.05	0.04	0.04	0.02
	4	0.23	0.16	0.13	0.12	0.04	0.03	0.03	0.02

Corrective factor Y, to be used for the filter element pressure drop calculation.
The values depend to the filter size and length and to the filter media.

Reference viscosity 30 mm²/s

Suction filters

Filter element	Nominal filtration N Series	
	P10	P25
SF 250	65	21

Return / Suction filters

Filter element	Absolute filtration			
	A10	A16	A25	
RSX 116	1	5.12	4.33	3.85
	2	2.22	1.87	1.22
RSX 165	1	2.06	1.75	1.46
	2	1.24	1.05	0.96
	3	0.94	0.86	0.61

Low & Medium pressure filters

Filter element	Type	Absolute filtration N-W Series					Nominal filtration N Series		
		A03	A06	A10	A16	A25	P10	P25	M25
CU 110	1	16.25	15.16	8.75	8.14	5.87	2.86	2.65	0.14
	2	12.62	10.44	6.11	6.02	4.15	1.60	1.49	0.12
	3	8.57	7.95	5.07	4.07	2.40	1.24	1.15	0.11
	4	5.76	4.05	2.80	2.36	1.14	0.91	0.85	0.05
CU 210	1	5.30	4.80	2.00	1.66	1.32	0.56	0.43	0.12
	2	3.44	2.95	1.24	1.09	0.70	0.42	0.35	0.09
	3	2.40	1.70	0.94	0.84	0.54	0.33	0.23	0.05
DN	016	7.95	7.20	3.00	2.49	1.98	0.84	0.65	0.18
	025	5.00	4.53	1.89	1.57	1.25	0.53	0.41	0.11
	040	3.13	2.66	1.12	0.98	0.63	0.38	0.32	0.08
CU 400	2	3.13	2.55	1.46	1.22	0.78	0.75	0.64	0.19
	3	2.15	1.70	0.94	0.78	0.50	0.40	0.34	0.10
	4	1.60	1.28	0.71	0.61	0.40	0.34	0.27	0.08
	5	1.00	0.83	0.47	0.34	0.20	0.24	0.19	0.06
	6	0.82	0.58	0.30	0.27	0.17	0.22	0.18	0.05
	CU 900	1	0.86	0.63	0.32	0.30	0.21	-	-
CU 950	2	1.03	0.80	0.59	0.40	0.26	-	-	0.05
	3	0.44	0.40	0.27	0.18	0.15	-	-	0.02
MR 630	7	0.88	0.78	0.36	0.34	0.16	0.12	0.96	0.47

FILTER SIZING Corrective factor

Corrective factor **Y**, to be used for the filter element pressure drop calculation.
The values depend to the filter size and lenght and to the filter media.

Reference viscosity 30 mm²/s

High pressure filters

Filter element	Absolute filtration N - R Series					Nominal filtration N Series	
	Type	A03	A06	A10	A16		A25
HP 011	1	332.71	250.07	184.32	152.36	128.36	-
	2	220.28	165.56	74.08	59.13	37.05	-
	3	123.24	92.68	41.48	33.08	20.72	-
	4	77.76	58.52	28.37	22.67	16.17	-
HP 039	1	70.66	53.20	25.77	20.57	14.67	4.90
	2	36.57	32.28	18.00	13.38	8.00	2.90
	3	26.57	23.27	12.46	8.80	5.58	2.20
HP 050	1	31.75	30.30	13.16	12.3	7.29	1.60
	2	24.25	21.26	11.70	9.09	4.90	1.40
	3	17.37	16.25	8.90	7.18	3.63	1.25
	4	12.12	10.75	6.10	5.75	3.08	1.07
	5	7.00	6.56	3.60	3.10	2.25	0.80
HP 065	1	58.50	43.46	23.16	19.66	10.71	1.28
	2	42.60	25.64	16.22	13.88	7.32	1.11
	3	20.50	15.88	8.18	6.81	3.91	0.58
HP 135	1	20.33	18.80	9.71	8.66	4.78	2.78
	2	11.14	10.16	6.60	6.38	2.22	1.11
	3	6.48	6.33	3.38	3.16	2.14	1.01
HP 320	1	10.88	9.73	5.02	3.73	2.54	1.04
	2	4.40	3.83	1.75	1.48	0.88	0.71
	3	2.75	2.11	1.05	0.87	0.77	0.61
	4	2.12	1.77	0.98	0.78	0.55	0.47
HP 500	1	4.44	3.67	2.30	2.10	1.65	0.15
	2	3.37	2.77	1.78	1.68	1.24	0.10
	3	2.22	1.98	1.11	1.09	0.75	0.08
	4	1.81	1.33	0.93	0.86	0.68	0.05
	5	1.33	1.15	0.77	0.68	0.48	0.04

Filter element	Absolute filtration N Series					Nominal filtration N Series	
	Type	A03	A06	A10	A16		A25
HF 320	1	3.65	2.95	2.80	1.80	0.90	0.38
	2	2.03	1.73	1.61	1.35	0.85	0.36
	3	1.84	1.42	1.32	1.22	0.80	0.35

Stainless steel high pressure filters

Filter element	Absolute filtration N Series					
	Type	A03	A06	A10	A16	A25
HP 011	1	332.71	250.07	184.32	152.36	128.36
	2	220.28	165.56	74.08	59.13	37.05
	3	123.24	92.68	41.48	33.08	20.72
	4	77.76	58.52	28.37	22.67	16.17
HP 039	2	70.66	53.20	25.77	20.57	14.67
	3	36.57	32.28	18.00	13.38	8.00
	4	26.57	23.27	12.46	0.88	5.58
	1	31.75	30.30	13.16	12.3	7.29
HP 050	2	24.25	21.26	11.70	9.09	4.90
	3	17.37	16.25	8.90	7.18	3.63
	4	12.12	10.75	6.10	5.75	3.08
	5	7.00	6.56	3.60	3.10	2.25
	1	20.33	18.80	9.71	8.66	4.78
HP 135	2	11.14	10.16	6.60	6.38	2.22
	3	6.48	6.33	3.38	3.16	2.14

Filter element	Absolute filtration H - U Series					
	Type	A03	A06	A10	A16	A25
HP 011	1	424.58	319.74	235.17	194.44	163.78
	2	281.06	211.25	94.53	75.45	47.26
	3	130.14	97.50	43.63	34.82	21.81
	4	109.39	82.25	36.79	29.37	18.40
HP 039	2	70.66	53.20	25.77	20.57	14.67
	3	36.57	32.28	18.00	13.38	8.00
	4	26.57	23.27	12.46	8.80	5.58
	1	47.33	34.25	21.50	20.50	14.71
HP 050	2	29.10	25.95	14.04	10.90	5.88
	3	20.85	19.50	10.68	8.61	4.36
	4	14.55	12.90	7.32	6.90	3.69
	5	9.86	9.34	6.40	4.80	2.50
	1	29.16	25.33	13.00	12.47	5.92
HP 135	2	14.28	11.04	7.86	7.60	4.44
	3	8.96	7.46	4.89	4.16	3.07

Step 1 Select "FILTERS"



Step 2 Choose filter group (Return Filter, Pressure Filter, etc.)



Step 3 Choose filter type (MPF, MPT, etc.) in function of the max working pressure and the max flow rate



Step 4 Push "PROCEED"

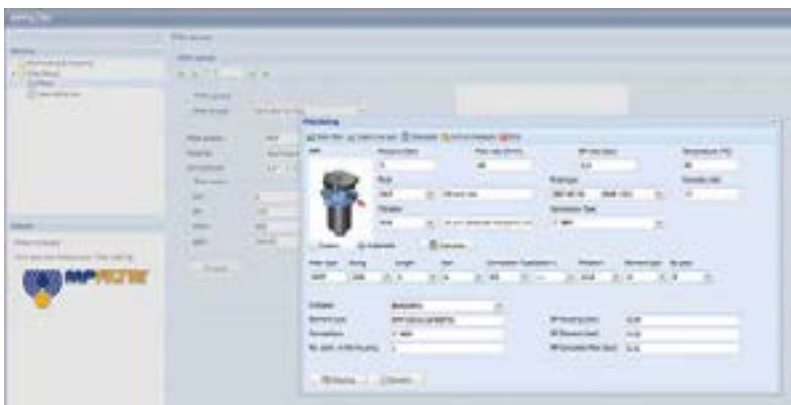

Step 5

Insert all application data to calculate the filter size following the sequence:

- working pressure
- working flow rate
- working pressure drop
- working temperature
- fluid material and fluid type
- filtration media
- connection type

Step 6

Push "CALCULATE" to have result; in case of any mistake, the system will advice which parameter is out of range to allow to modify/adjust the selection

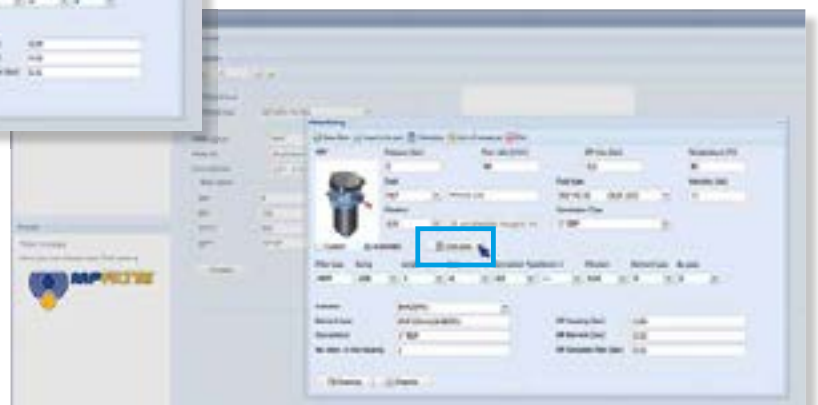

Step 7

Download PDF Datasheet "Report.aspx" pushing the button "Drawing"

LMD 400-401 & 431 series

Maximum pressure up to 16 bar - Flow rate up to 590 l/min



Technical data

Low & Medium Pressure filters Maximum pressure up to 16 bar - Flow rate up to 590 l/min

Filter housing materials

- Head: Anodized Aluminium
- Housing: Anodized Aluminium
- Manifolds: Steel - Painted black
- Bypass valve: Steel
- 3-way ball valve: Steel housings - Stainless Steel ball
- Valve: Phosphated Steel - Stainless Steel

Seals

FPM series V

Temperature

From -25° C to +110° C

Pressure

- Working pressure: 1.6 MPa (16 bar)
- Test pressure: 2.5 MPa (25 bar)

Connections

- LMD 400-401: In-line Inlet/Outlet
- LMD 401: Same side
- LMD 400-401-431: In-Line

Bypass valve

- Opening pressure 3.5 bar ±10%
- Other opening pressures on request.

Note

LMP 400 - 401 - 431 filters are provided for vertical mounting

Δp element type

- Microfibre filter elements - series N - W: 20 bar
- Fluid flow through the filter element from OUT to IN.

Weights [kg] and volumes [dm³]

	Weights [kg]			Volumes [dm ³]				
	Length	4	5	6	Length	4	5	6
LMD 400 - 401		60	65	72		20	28	33
LMD 431		-	68	78		-	28	33

Hydraulic symbols

LMD 400-401-431-951

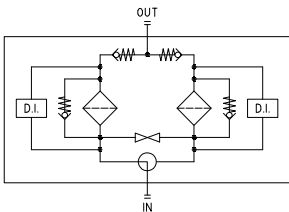

P2 EXECUTION



Execution P02
"Internal tube for reduced flow rate"
is recommended for flow rate
values below 150 l/min.

The use of option P02
makes it easier to fill the housing
with the operating fluid.

"Internal tube for reduced flow rates"

The curves are plotted using mineral oil with density of 0.86 kg/dm³ in compliance with ISO 3968.

Δp varies proportionally with density.

Pressure drop

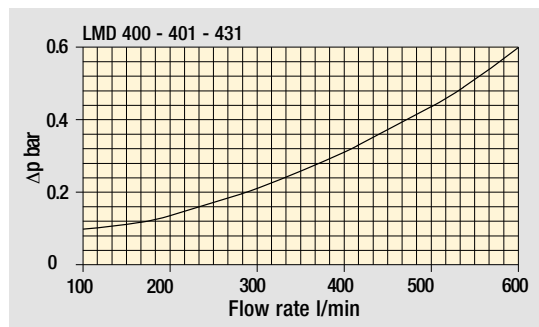

Filter housings Δp pressure drop

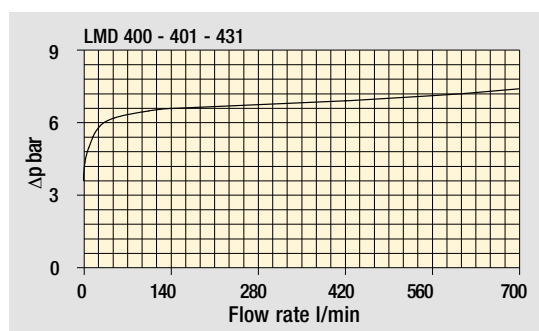

Bypass valve pressure drop

Focus on

- A Breather plug G3/8" - A/F 8
- B Indicator port Plug T2 - A/F 30
- C Compensation valve
- D Oil drain plug G3/8" - A/F 8

LMP 400 - 401 - 431

Fit one differential indicator for individual filter assembly.

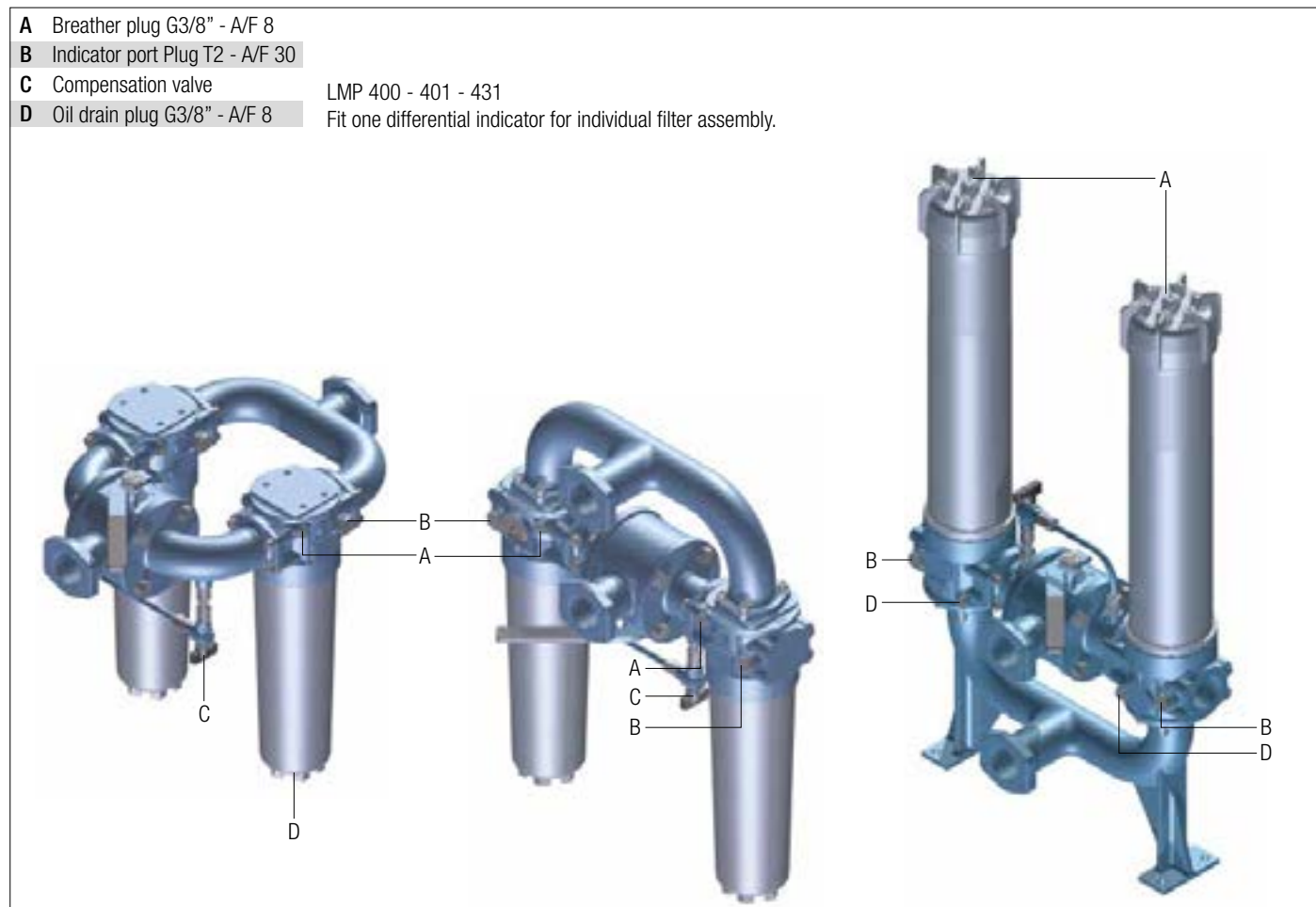

LMD400-401

Designation & Ordering code

COMPLETE FILTER

Series and size LMD400 LMD401		Configuration example: LMD401 4 B V F1 A10 N P01									
Length 4 5 6											
Bypass valve S Without bypass B 3.5 bar											
Seals and treatments		Filtration rating									
V FPM		Axx	Mxx	Pxx							
Z FPM compatible with fluids HFA-HFB-HFC											
Connections		LMD400	LMD401								
F1 2 1/2" SAE 3000 psi/M											
F2 2 1/2" SAE 3000 psi/UNC											
F3 2 1/2" SAE 3000 psi/M, In-line connections											
F4 2 1/2" SAE 3000 psi/UNC, In-line connections											
Filtration rating (filter media)											
A03 Inorganic microfiber 3 µm											
A06 Inorganic microfiber 6 µm											
A10 Inorganic microfiber 10 µm											
A16 Inorganic microfiber 16 µm											
A25 Inorganic microfiber 25 µm											
M25 Wire mesh 25 µm											
M60 Wire mesh 60 µm											
M90 Wire mesh 90 µm											
P10 Resin impregnated paper 10 µm											
P25 Resin impregnated paper 25 µm											
Element Δp N 20 bar		Execution							Filter length		
		P01 MP Filtri standard							4	5	6
		P02 Maintenance from the bottom of the housing									
		Pxx Customized									

FILTER ELEMENT

Element series and size CU400		Configuration example: CU400 4 A10 V N P01									
Element length 4 5 6											
Filtration rating (filter media)											
A03 Inorganic microfiber 3 µm											
A06 Inorganic microfiber 6 µm											
A10 Inorganic microfiber 10 µm											
A16 Inorganic microfiber 16 µm											
A25 Inorganic microfiber 25 µm											
M25 Wire mesh 25 µm											
M60 Wire mesh 60 µm											
M90 Wire mesh 90 µm											
P10 Resin impregnated paper 10 µm											
P25 Resin impregnated paper 25 µm											
Seals		Filtration rating									
V FPM		Axx	Mxx	Pxx							
Z FPM compatible with fluids HFA-HFB-HFC											
Element Δp N 20 bar		Execution							Filter length		
		P01 MP Filtri standard							4	5	6
		Pxx Customized									

ACCESSORIES

Differential indicators		page			page
DEA	Electrical differential indicator	419	DTA	Electronic differential indicator	422
DEM	Electrical differential indicator	419-420	DVA	Visual differential indicator	422
DLA	Electrical / visual differential indicator	420-421	DVM	Visual differential indicator	422
DLE	Electrical / visual differential indicator	421			
Additional features		page			
T2	Plug	423			

LMD400-401

Dimensions

LMD400	
Length 4	
Connections	R
F1	M12
F2	1/2" UNC
F3	M12
F4	1/2" UNC

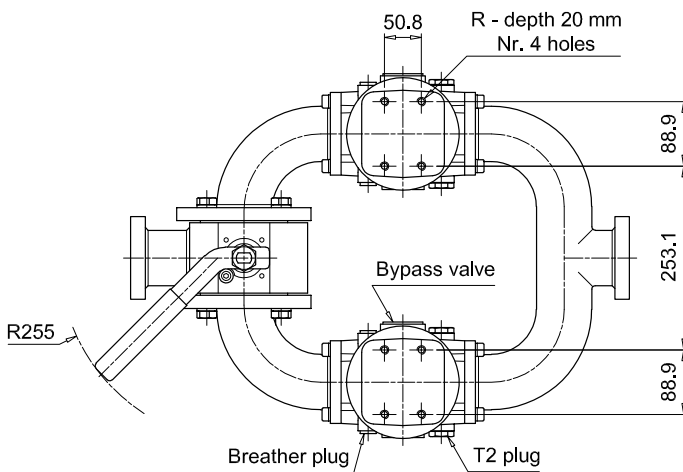
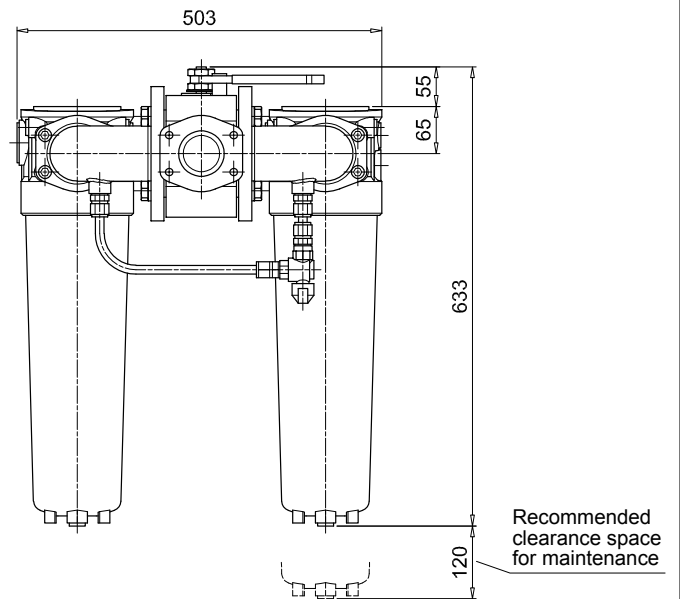
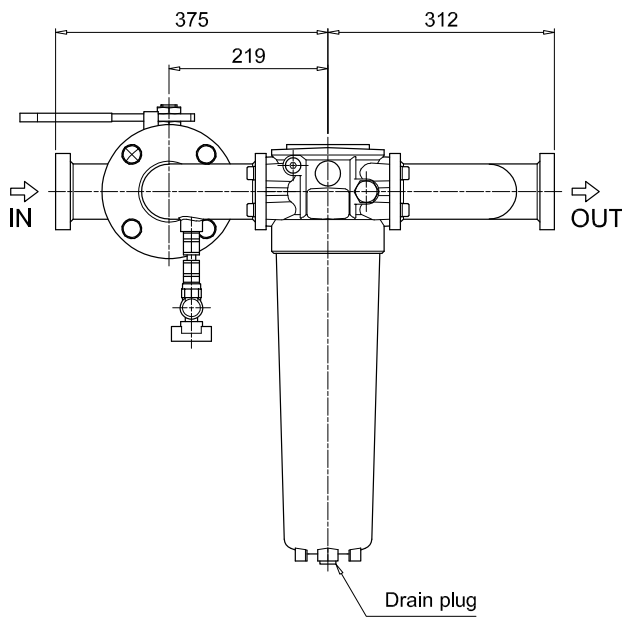

T2 plug =
connection for differential indicator

LMD400-401

Dimensions

LMD400

Length 5 - 6

Filter length	H [mm]	H2 [mm]	
		Execution P01	Execution P02
5	883	120	660
6	1213	120	690

Connections	R
F1	M12
F2	1/2" UNC
F3	M12
F4	1/2" UNC

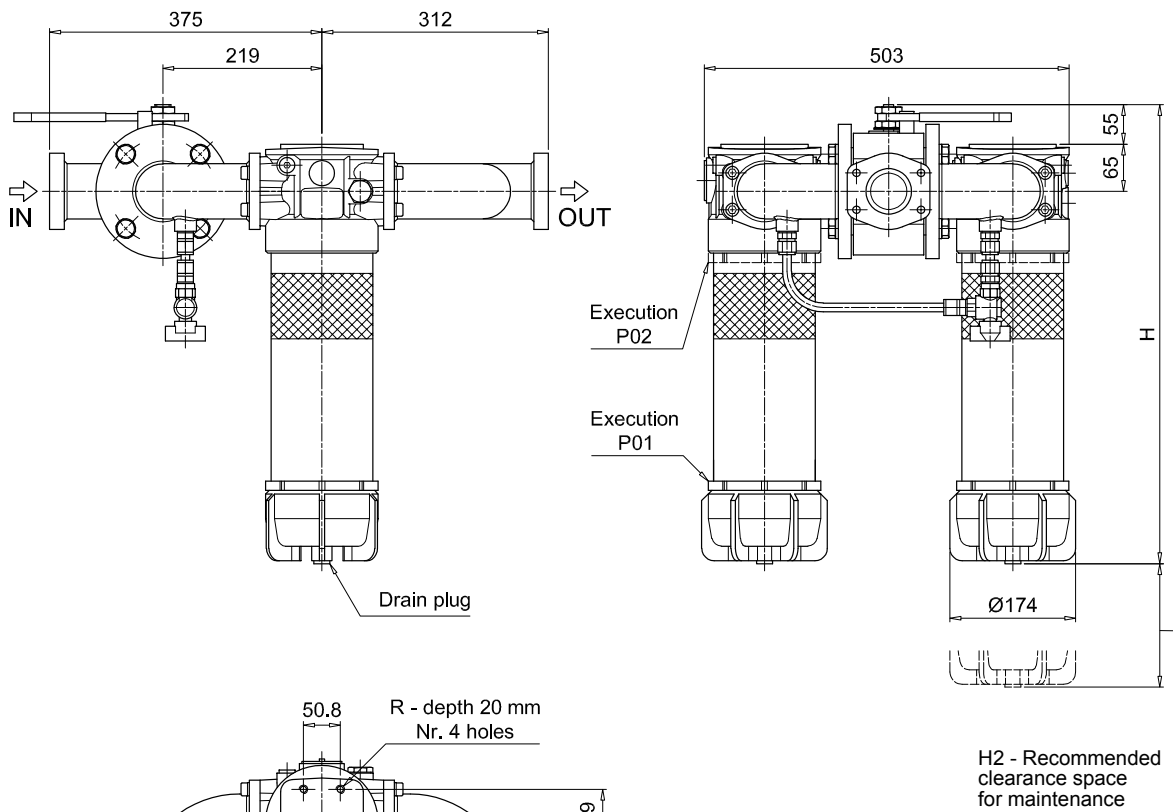

LMD400-401

Dimensions

LMD401	
Length 4	
Connections	R
F1	M12
F2	1/2" UNC
F3	M12
F4	1/2" UNC

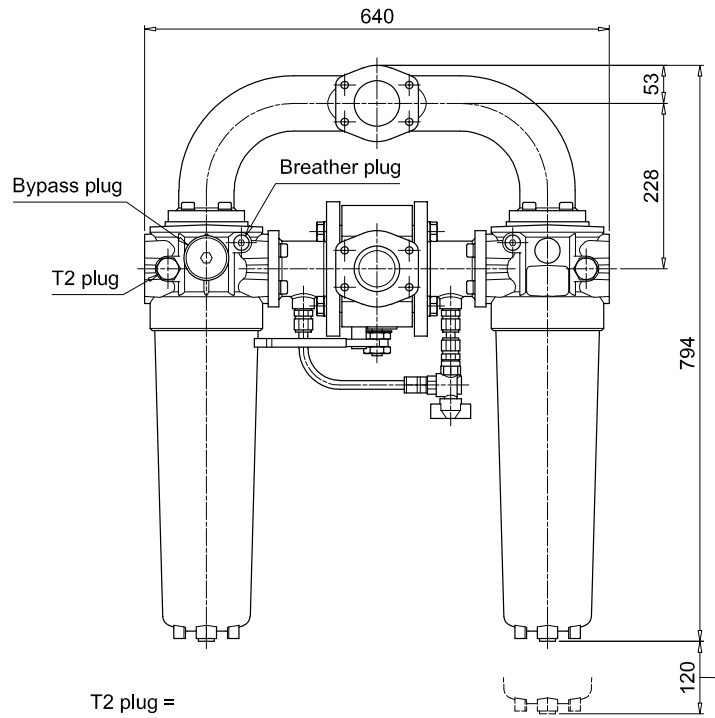
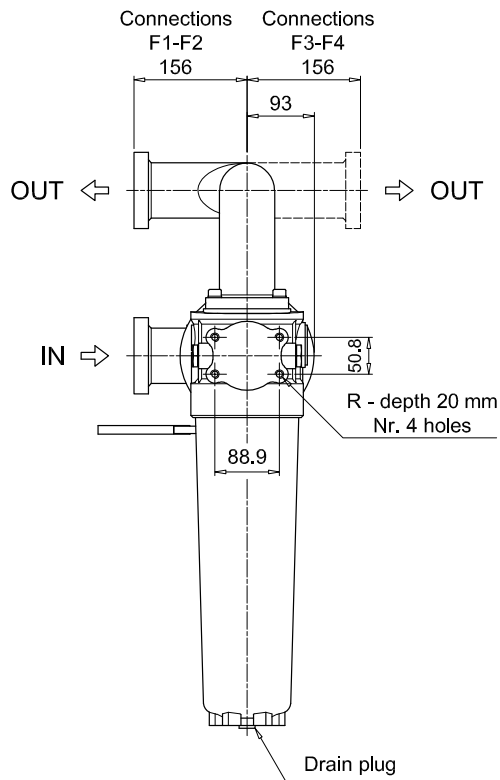

T2 plug =
connection for differential indicator

Recommended
clearance space
for maintenance

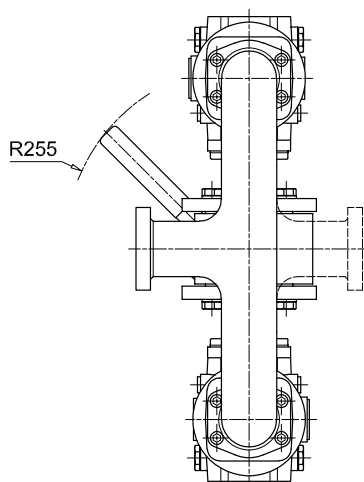

LMD400-401

Dimensions

LMD401

Length 5 - 6

Filter length	H [mm]	H2 [mm]	
		Execution P01	Execution P02
5	1044	120	660
6	1374	120	690

Connections	R
F1	M12
F2	1/2" UNC
F3	M12
F4	1/2" UNC

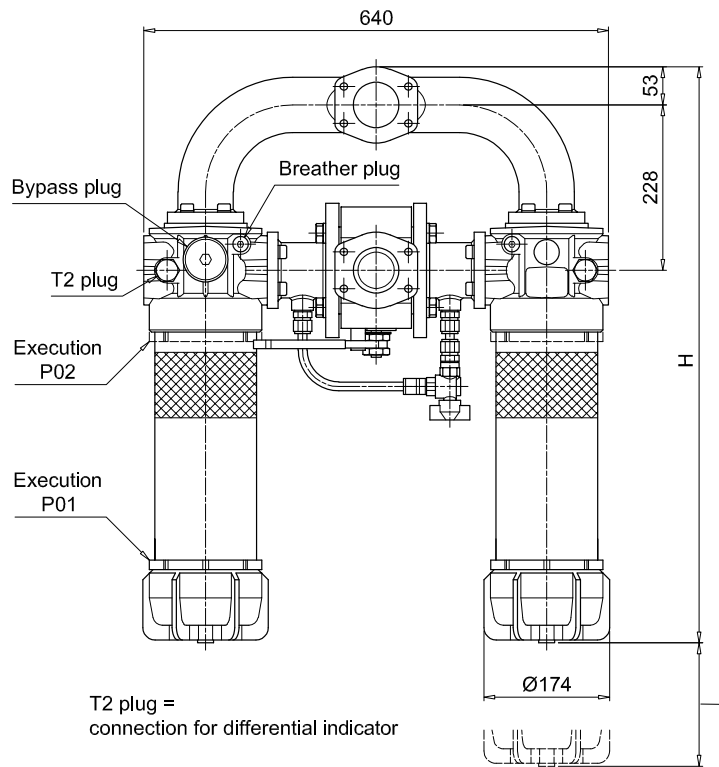
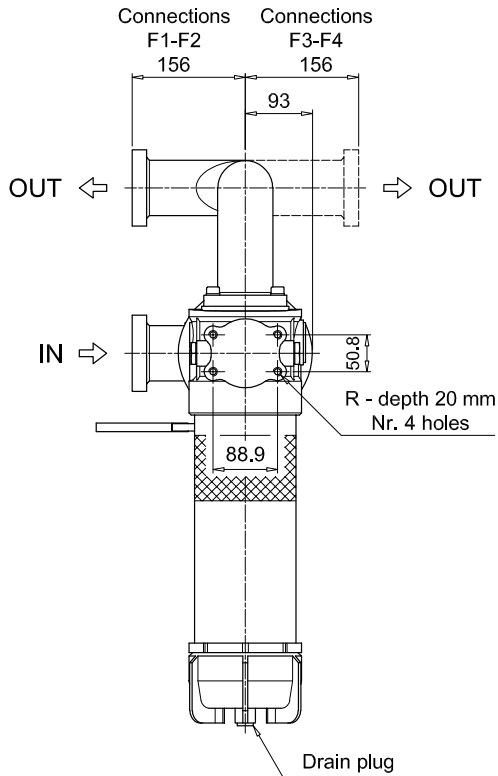

H2 - Recommended clearance space for maintenance

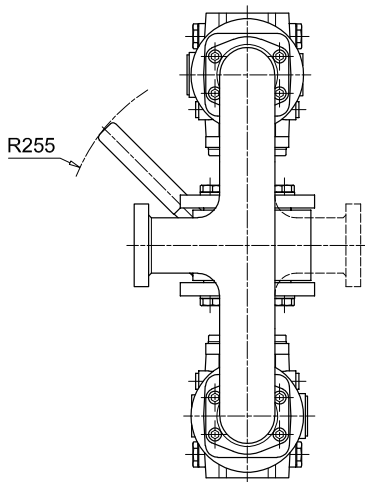

LMD431

Designation & Ordering code

COMPLETE FILTER

Series and size LMD431	Configuration example: LMD431 5 B V F1 A10 N P01									
Length 5 6										
Bypass valve S Without bypass B 3.5 bar										
Seals and treatments	Filtration rating									
V FPM	Axx	Mxx	Pxx							
Z FPM compatible with fluids HFA-HFB-HFC	•	•	•							
Connections										
F1 2 1/2" SAE 3000 psi/M										
F2 2 1/2" SAE 3000 psi/UNC										
F3 2 1/2" SAE 3000 psi/M, In-line connections										
F4 2 1/2" SAE 3000 psi/UNC, In-line connections										
Filtration rating (filter media)										
A03 Inorganic microfiber 3 µm	M25 Wire mesh 25 µm									
A06 Inorganic microfiber 6 µm	M60 Wire mesh 60 µm									
A10 Inorganic microfiber 10 µm	M90 Wire mesh 90 µm									
A16 Inorganic microfiber 16 µm	P10 Resin impregnated paper 10 µm									
A25 Inorganic microfiber 25 µm	P25 Resin impregnated paper 25 µm									
			Element Δp		Execution					
			N 20 bar		P01 MP Filtri standard					
					P02 With internal reduced flow rate tube					
					Pxx Customized					

FILTER ELEMENT

Element series and size CU400	Configuration example: CU400 5 A10 V N P01						
Element length 5 6							
Filtration rating (filter media)							
A03 Inorganic microfiber 3 µm	M25 Wire mesh 25 µm						
A06 Inorganic microfiber 6 µm	M60 Wire mesh 60 µm						
A10 Inorganic microfiber 10 µm	M90 Wire mesh 90 µm						
A16 Inorganic microfiber 16 µm	P10 Resin impregnated paper 10 µm						
A25 Inorganic microfiber 25 µm	P25 Resin impregnated paper 25 µm						
Seals	Filtration rating						
V FPM	Axx	Mxx	Pxx				
Z FPM compatible with fluids HFA-HFB-HFC	•	•	•				
			Element Δp		Execution		
			N 20 bar		P01 MP Filtri standard		
					Pxx Customized		

ACCESSORIES

Differential indicators	page		page
DEA Electrical differential indicator	419	DTA Electronic differential indicator	422
DEM Electrical differential indicator	419-420	DVA Visual differential indicator	422
DLA Electrical / visual differential indicator	420-421	DVM Visual differential indicator	422
DLE Electrical / visual differential indicator	421		
Additional features		page	
T2 Plug		423	

LMD431

Filter length	H [mm]	H2 [mm]
5	1161	660
6	1491	690

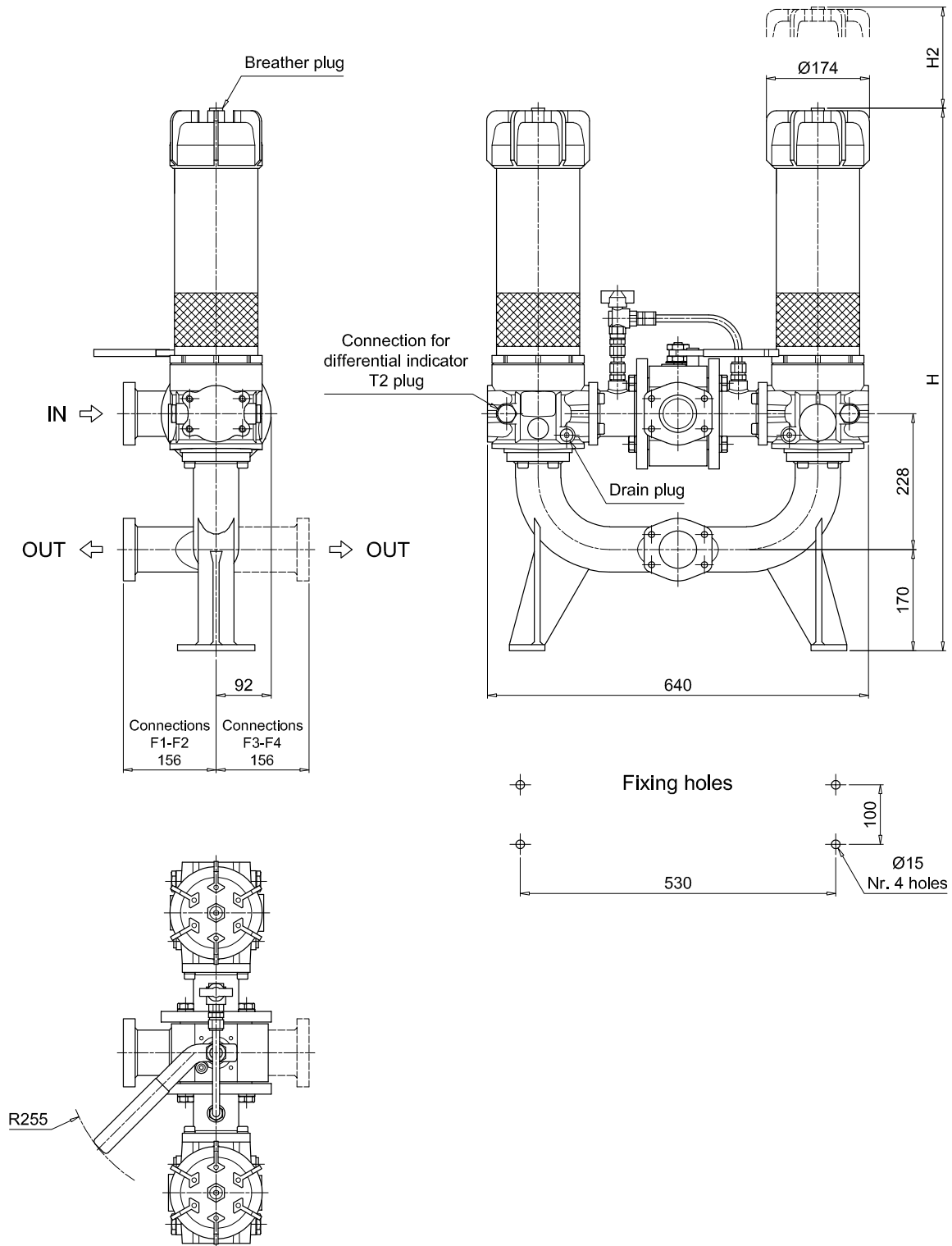

Order number for spare parts

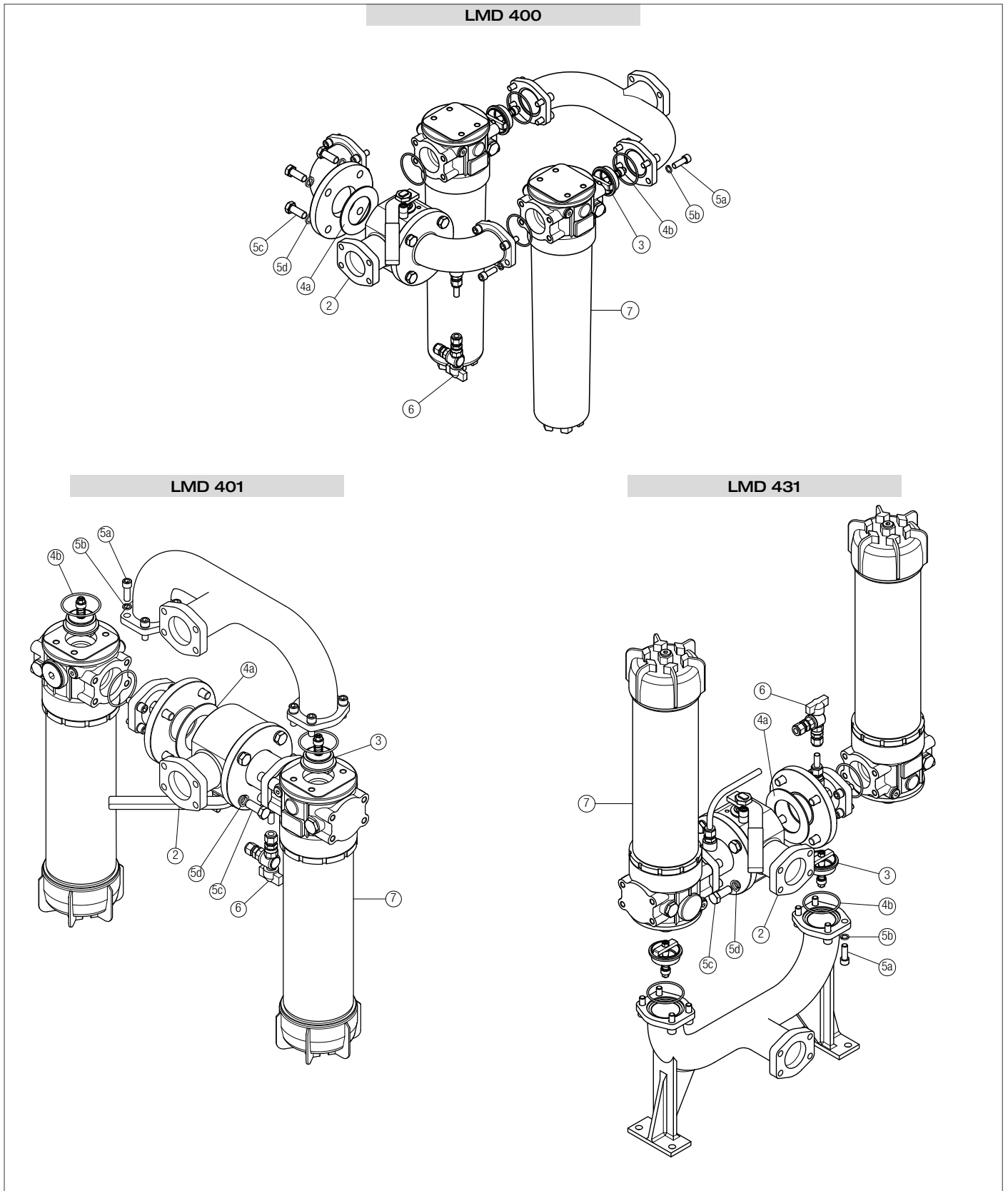

Item:	Q.ty: 1 pc. 2		Q.ty: 2 pcs. 3	Q.ty: 1 pc. 4 (4a ÷ 4b)	Q.ty: 1 pc. 5 (5a ÷ 5d)	Q.ty: 1 pc. 6	Q.ty: 2 pcs. 7
Filter series	3-way ball valve PN 16 2 1/2" SAE 3000 psi/M 2 1/2" SAE 3000 psi/UNC		One-way valve	Seal Kit	Threaded fasteners kit	Kit ball valve with hose fitting	Filter See order table
LMD 400 - 401 - 431	02001440	02001441	02001429	02050399	02049062	02025043	LMP400xF2.....