

CycloneConcept

pmchydraulics

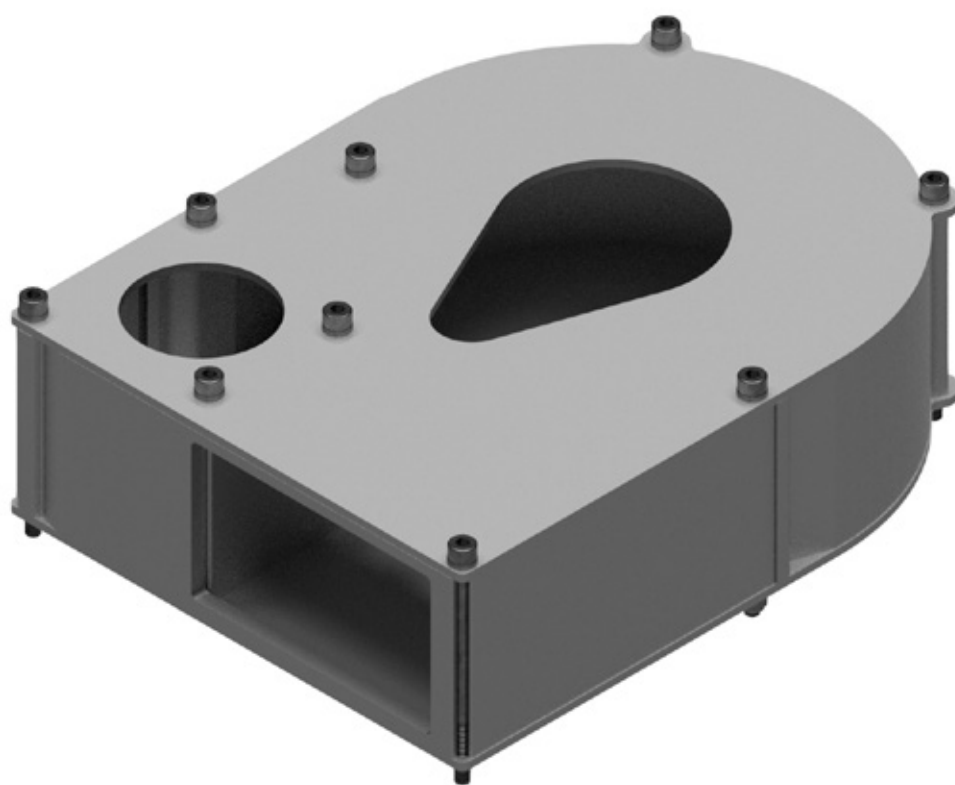

The C350 and C650 Cyclone meet your need
for compact hydraulic tanks

The PMC Hydraulics C350 and C650 Cyclone meet your need for compact hydraulic tanks

A traditional hydraulic system has a large tank volume, allowing oil to pass through at a low speed and air to be vented. The PMC cyclone is based on a new technology which forces oil venting, making it possible to use a smaller tank.

Usually **the tank volume and weight reduction lies between 67 % and 90 %**, depending on cylinder features and differential volumes. The top of the PMC cyclone only needs to be covered with oil at low oil level operations. The C350 and C650 Cyclones are patented products which can be configured with different inlet and outlet adapters. In most cases a return line filter is mounted on top of the inlet inside the tank.

Active air separation

The **active air separation** works regardless of the return flow. This is made possible by the 0,5 bar cyclone spring that opens due to pressure created by the return flow. This in turn leads to a high velocity inside the cyclone, creating strong internal radial forces which separate air from oil, moving air to the center of the cyclone.

The cyclones are able to create a positive overpressure in suction ports up to 0,15 bar. They can also accelerate oil from the tank if the return flow is smaller than the pump flow.

The C350 Cyclone is designed for a flow up to 350 liters per minute and the C650 Cyclone is designed for a flow up to 650 liters per minute.

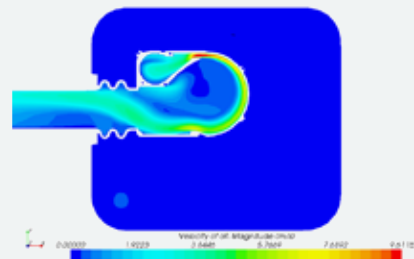
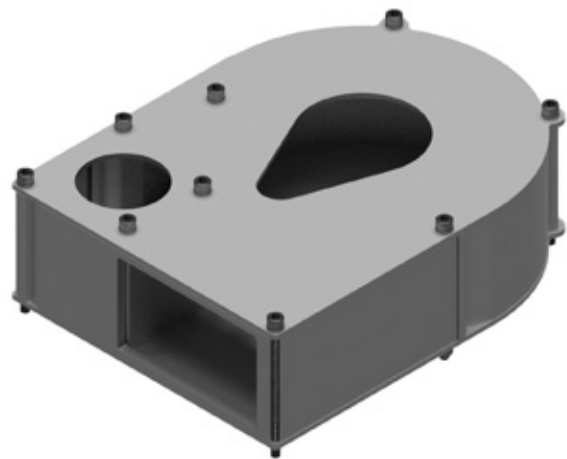

This image shows a cyclone in the middle of a hydraulic tank, seen from above. The flow enters through the cyclone inlet in the upper left corner. The oil flows at a speed of >10 m/s as the return pressure forces the 0,5 bar cyclone spring to open. The flow then enters the cyclone (here colored red) with a high speed. In the tank outlet (pictured left) the speed is still high.

A fluid simulation analysis shows that after only one passage, 9 % free air is reduced to less than 1,5 %.

UP TO

90%

WEIGHT REDUCTION

The patented CycloneConcept for hydraulic units saves space, energy and the environment.

C350

MAX. FLOW	350 l/min open spring	SPRING PRESSURE	0,5 bar
MAX. DIFF FLOW	100 l/min with tear drop air hole	PRESSURE DROP	0,5 bar up to 350 l/min
MAX. DIFF FLOW	60 l/min with 50 mm air hole	LENGTH	247 mm
OUTLET	Rectangular or circular	WIDTH	187 mm
INLET	48 mm port	HEIGHT	77 mm
MAX. PRESSURE	2 bar	MATERIAL	Aluminum



C350 TRL
1205266 Cyclone with tear drop air hole and rectangular outlet, left inlet



C350 TRR
1205267 Cyclone with tear drop air hole and rectangular outlet, right inlet



1177186 Rectangular outlet bellow



C350 CCL
1205268 Cyclone with circular air hole and circular outlet, left inlet



C350 CCR
1205269 Cyclone with circular air hole and circular outlet, right inlet



137014 Round outlet bellow



1202021 Rectangular outlet seal

C650

MAX. FLOW	650 l/min open spring	SPRING PRESSURE	0,5 bar
MAX. DIFF FLOW	100 l/min with tear drop air hole	PRESSURE DROP	0,5 bar up to 650 l/min
MAX. DIFF FLOW	60 l/min with 50 mm air hole	LENGTH	247 mm
OUTLET	Rectangular or circular	WIDTH	187 mm
INLET	48 mm port	HEIGHT	127 mm
MAX. PRESSURE	2 bar	MATERIAL	Aluminum



C650 TCL
1205271 Cyclone with tear drop air hole and circular outlet, left inlet



C650 TCR
1205272 Cyclone with tear drop air hole and circular outlet, right inlet



123169 Round outlet bellow



C650 CCL
1205274 Cyclone with circular air hole and circular outlet, left inlet



C650 CCR
1205275 Cyclone with circular air hole and circular outlet, right inlet



1189925 Round outlet seal

Accessories for C350 and C650



Round inlet bellow*

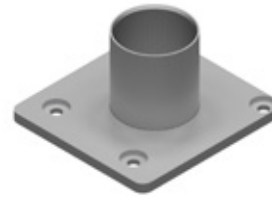

Inlet hose adapter 1 1/2"*

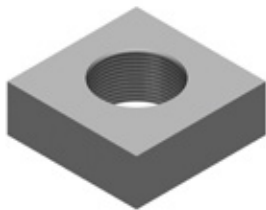

Inlet manifold BSPP G11/2"*



Inlet manifold for filter with extension pipe*

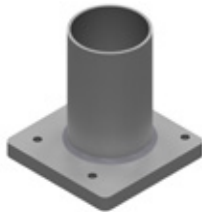

Inlet hose adapter 2"*

*For all accessories, please contact PMC Hydraulics
(see contact information on the back page)

CYCLONE CX50 XXX

1.

2.

3.

4.

1. SIZE

C350
C650

2. AIR HOLE TYPE

T = TEAR
C = CIRCULAR

3. OUTLET TYPE

R = Rectangular
C = Circular

4. INLET HANDEDNESS

R = Right inlet
L = Left Inlet

Example: Cyclone C350 TRL → Cyclone for 350LPM with tear drop air hole, rectangular outlet and left inlet

PMC Hydraulics AB

Askims Verkstadsväg 15
436 34 Askim GOTHENBURG
Sweden

Phone: +46 31 28 98 40

PMC Hydraulics Oy

Teknobulevardi 3-5
01530 VANTAA
Finland

Phone: +358 20 770 9700

PMC Hydraulics A/S

Baltorpbakken 1
2750 Ballerup COPENHAGEN
Denmark

Phone: +45 75 14 44 44

www.pmchdraulics.com